

Head Office

Wellington

PO Box 35-063
Naenae
Lower Hutt 5041
17 Eastern Hutt Rd
Wingate
Lower Hutt 5019
Tel (04) 567-3229
Fax (04) 567-3644

www.pertronic.co.nz

sales@pertronic.co.nz
tech@pertronic.co.nz

Auckland Office

PO Box 15-867
New Lynn
Auckland 0640
359 Onehunga Mall
Onehunga
Auckland 1061
Tel (09) 633-0226
Fax (09) 633-0228

Product Overview:

The **BACnet Gateway** facilitates communication between a Pertronic F120A or F220 fire alarm control panel and a Building Management System (BMS). The gateway monitors data broadcast by the fire alarm control panel and reports specific items to the BMS using the BACnet protocol.

Options in the configuration software allow the gateway to be configured to create BACnet objects representing a wide range of data items from the fire alarm control panel.

The gateway system consists of a contemporary controls BASGatewayLX Gateway Module connected to a Pertronic Industries GPIB-M Modbus Interface. The system is normally installed inside the fire alarm cabinet. It connects to the BMS physical network via an Ethernet port.



BASGatewayLX Gateway Module

Features:

- ▶ BACnet interface between Pertronic F120A or F220 fire alarm control system and building management system
- ▶ 10/100 Mbps Ethernet with auto-negotiation and Auto-MDIX
- ▶ Configurable to create BACnet objects representing various panel states such as:
 - ▶ Fire zone 'Alarm' and 'Isolate' states
 - ▶ Fire alarm system global status information including 'Sprinkler', 'Evacuate', along with fault and communication system status
 - ▶ Fire alarm system software entities such as 'Brigade', 'Smoke Alarm', 'Call Point Alarm', as specified in the panel configuration
 - ▶ The F120A or F220 fire alarm control panel can be configured to broadcast data items selected from a large number of entities (refer to the F120 or F220 technical manual and BACnet gateway installation note for details)
- ▶ GPIB Modbus module has RS232 port for configuration
- ▶ Optically isolated RS485 port for connection to fire alarm panel



Certificate No:
205487-2016-
AQ-AUS-JAS-ANZ

Specifications:

▶ Dimensions		
▶ CCS BACnet Gateway	41 x 131 x 100 mm	W x H x D mm
▶ GPIB Board	182 x 97 x 20 mm	W x H x D mm
▶ DC Current	280 mA @ 24 Vdc	
▶ Communications	Ethernet, RS232	
▶ Ethernet Port		
▶ Compliance	IEEE 802.3	
▶ Protocol	BACnet/IP, Modbus TCP	
▶ Data Rate	10 Mbps, 100 Mbps	
▶ Physical Layer	10BASE-T, 100BASE-TX	
▶ Maximum Cable Length	100 m	
▶ Wiring/Connection		
▶ Ethernet Port	Shielded RJ-45	
▶ Power In	12 to 18 AWG	

Wiring Diagram:

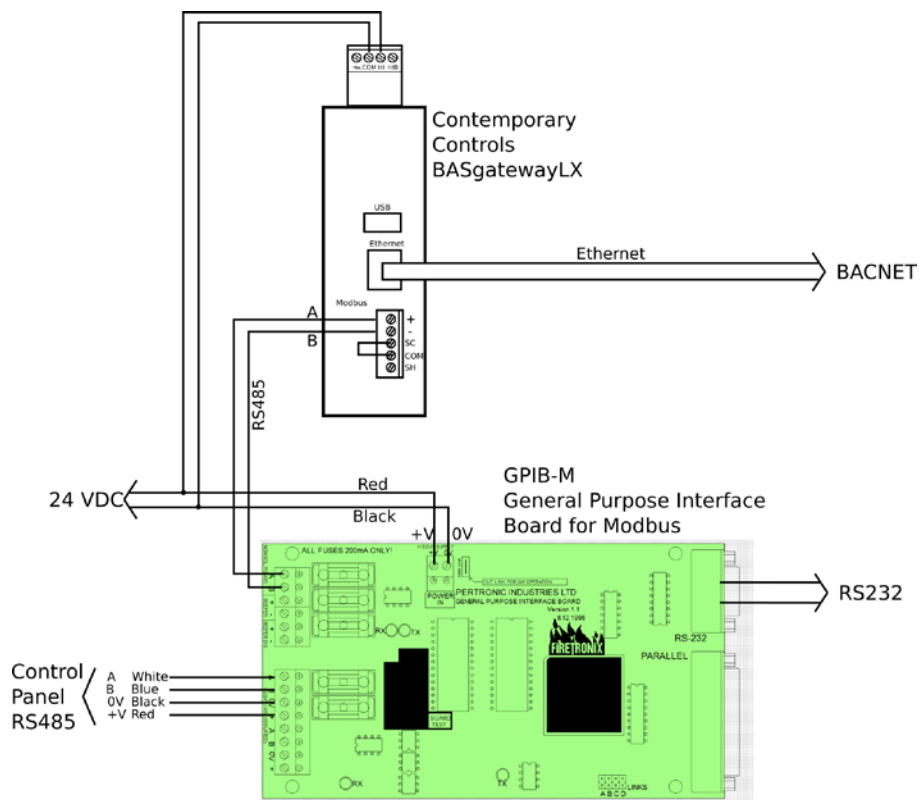

Ordering Information:

Product Code	Description
BASGLX-M1	BASgatewayLX Modbus to BACnet Gateway (Requires a Modbus GPIB)
GPIB-MF120	GP Interface Board - Modbus for F120A or F220

PERTRONIC INDUSTRIES LTD

Head Office:

17 Eastern Hutt Rd, Wingate, Lower Hutt 5019
 Telephone (04) 567-3229 Fax (04) 567-3644

www.pertronic.co.nz
 sales@pertronic.co.nz
 tech@pertronic.co.nz

Auckland Office:

359 Onehunga Mall, Onehunga, Auckland 1061
 Telephone (09) 633-0226 Fax (09) 633-0228

'Pertronic' and 'Firetronix' are registered trademarks of Pertronic Industries Ltd