

PERTRONIC INDUSTRIES LTD

FIREBITS

March 2010

Scott Base Protected By Pertronic F120 Panel



Scott Base has been New Zealand's permanent base in Antarctica since 1959, providing services and accommodation for the many research parties and groups who visit the region in the summer. The Base is located on Ross Island in the Ross Sea region of Antarctica, 3832 km from Christchurch and 1353 km from the South Pole. Acting as a support base for events as diverse as the expeditions of Sir Edmund Hillary to the search and recovery operation following the Mt. Erebus disaster, Scott Base holds a special place in the minds of many New Zealanders.

As with any remote location, the risk of fire is a constant concern. Around 105,000 litres of water is held at all times for the sprinkler systems, and the linkways between the buildings can be closed off or demolished to prevent the spread of fire. The fire detection system has recently undergone a major upgrade, with a Pertronic F120 fire control panel located in the main admin area and analogue addressable smoke detection installed through most buildings. In some of the more remote buildings the existing conventional detection

Continued on page 4



Enhancements to F4 Conventional Panels

The Pertronic F4 fire control panel has proven itself as a reliable and cost-effective four zone panel with brigade connection capability, plus the ability to support a sprinkler connection. Some recent changes in installation applications, combined with customer feedback, has led to the following enhancements being introduced to all F4 panels produced from March onwards:

- Fire and Defect changeover contacts added - this addition, together with an 'Aux Fire Isolate' switch eliminates the need to install the (optional) Auxiliary Relay Board, although this board can still be installed if additional relay outputs are required (provided the panel is not fitted with a Type-5 Sound Control Board). As a result of this addition, all SGD control signals are now switch contacts.
- An additional IDC connector, labelled 'BNC EXT LED' is provided to allow connection of an LED on the panel's index to indicate devices are not Brigade calling in a Type 5 application (used in conjunction with Type-5 Sound Control Board).
- When the F4 panel is being used in a Type 5 application, with a Type-5 Sound Control Board, circuit one can now be configured as a Type 5 zone or as a common area (Type 4) zone.

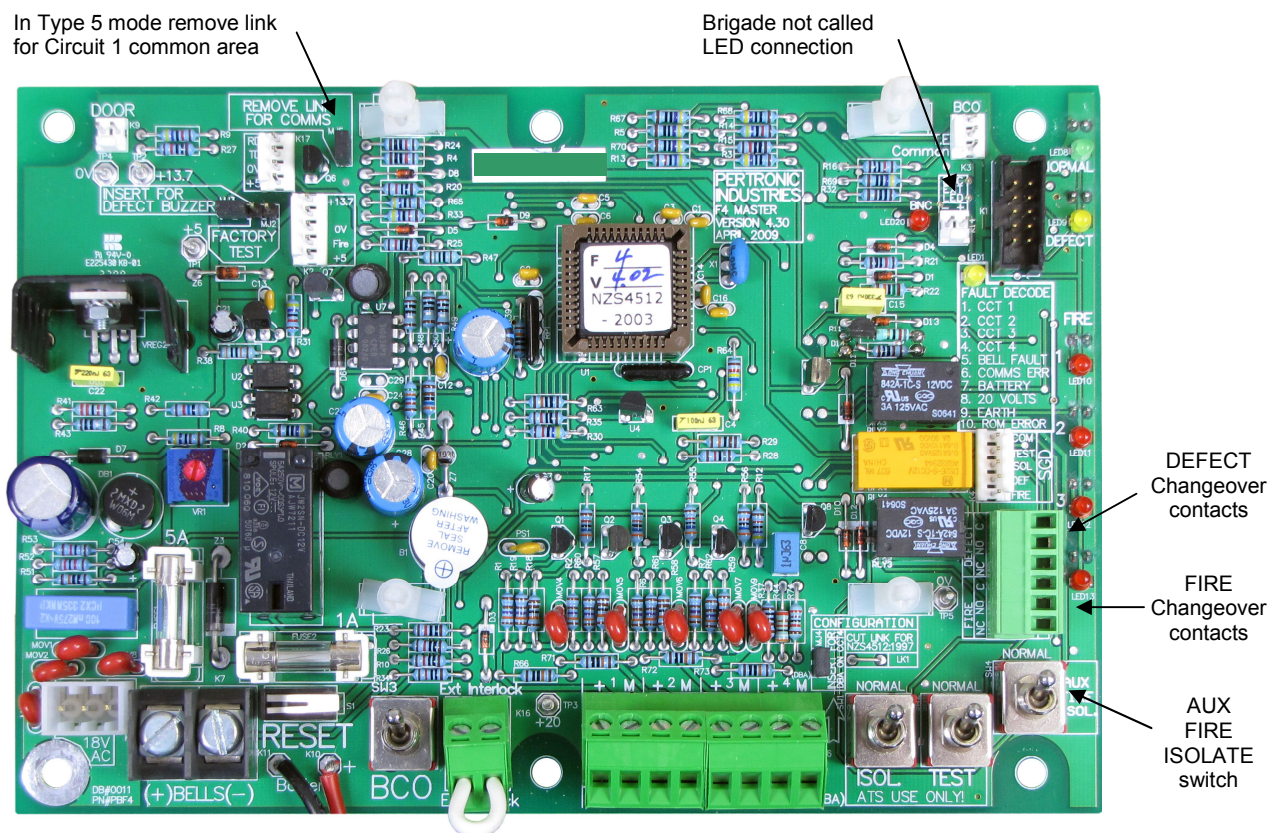

The following circuit configuration options are now available with F4 panels:

- **Type 2, Type 3, Type 4 installations**
 - Circuits 1,2,3,4 support detection zones.
 - Circuits 1,2,3 support detection zones with Circuit 4 as a sprinkler input.
- **Type 5 installations**
 - Circuits 1,2,3,4 support Type 5 detection zones.
 - Circuits 1,2,3 support Type 5 detection zones with Circuit 4 as a sprinkler input.
 - Circuits 2,3,4 support Type 5 detection zones with Circuit 1 as a common area.
 - Circuits 2,3 support Type 5 detection zones with Circuit 1 as a common area and Circuit 4 as a sprinkler input.

An updated F4 product manual is available for contractors to access on the Pertronic web site.

Intrinsically Safe Analogue Addressable Smoke Detector

System Sensor's 22051EISE analogue addressable photoelectric smoke sensor is an intrinsically safe detector designed specifically to provide fire protection in the most hazardous environments, and is engineered so that it cannot become an ignition source in areas where potentially explosive atmospheres are likely to occur. Compatible with other System Sensor analogue addressable detectors and using the same plug-in base, the 22051EISE is approved by BASEEFA to EEx ia IICT5, meaning it is suitable for use in up to Zone 0 hazardous areas and with most gases, excluding hydrogen and acetylene.

The 22051EISE must be used in conjunction with a System Sensor IST200 Translator Module and a Y72221 Galvanic Isolator, installed as indicated in the wiring schematic (right). Up to 15 detectors can be connected to one Translator Module and Galvanic Isolator, with the detector's analogue addressable technology giving the added benefit of unique address identification of any detector in alarm.

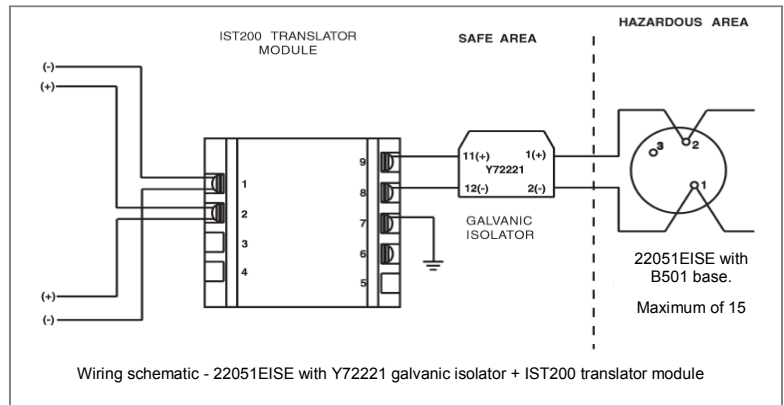

Detailed technical information is available on the Pertronic web site, listed under Products/Hazardous Areas.

M500C Relay Modules Replaced

System Sensor's analogue addressable M500C control module has been discontinued and will be replaced with two new modules - the M500S monitored control module and the M500R non-monitored relay module. The two new modules have the same dimensions and installation mounts as the superseded M500C module.

The **M500S** control module provides end-of-line monitoring of wiring circuits for load devices that require external power to operate, e.g. 100V speakers, sounders or strobes. The **M500R** relay module contains two isolated sets of Form C contacts which are switched on command from the control panel - there is no end-of-line monitoring with this module.

Data sheets and installation notes for these two new modules are available from the Pertronic web site, listed under Products/Analogue Addressable Systems/Modules. M500C modules will continue to be supplied from our Lower Hutt warehouse until stocks run out, with orders then switched to the new modules. Customers are asked to take care in ordering the new modules to ensure they receive the correct module type for each particular application.

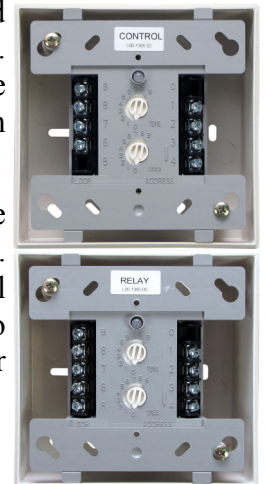

The Long Hot Summer - And Bugs In Detectors

This past summer has been hotter and drier than recent summers in many parts of the country. During this fine weather we have received more reports than normal of smoke detectors false alarming for no apparent reason. In many cases these alarms have been caused by bugs inside the detectors - their movement around the detection chamber is enough to cause an alarm. System Sensor advised some years ago that the hotter and drier the climate, the greater the incidence of bugs in detectors - they appear to like a cool dark place to lay their eggs. Even though the current models of photoelectric detectors have a much smaller mesh area to restrict bug access, some bugs still find their way inside.

A number of these detectors that have false alarmed get returned to our offices for analysis. It is important when removing these detectors from their base for return to Pertronic to place them immediately in a zip lock plastic bag to ensure any chamber contamination is retained. It is also important for us to be given information about the installation - the type of site, the environment (eg. can bugs be seen around the detectors externally), the type of fire panel, etc, to help us determine the exact cause of the false alarm.

PERTRONIC INDUSTRIES LTD

17 Eastern Hutt Rd, Wingate, Wellington. PO Box 35-063, Nae Nae. Phone (04) 5673229, Fax (04) 5673644.
www.pertronic.co.nz email: sales@pertronic.co.nz

AUCKLAND OFFICE:

119 Lansford Crescent, Avondale. PO Box 15-867, New Lynn. Phone (09) 820 8228 , Fax (09) 820 8284

Continued from page 1

is interfaced back to the F120 panel. Vesda detectors in the workshops and intrinsically safe detection in the hazardous areas are also connected to the F120 panel. Most of the installation was carried out by electrical staff at Scott Base, with overall project supervision, panel programming and on-site final commissioning provided by Fire Fighting Pacific Canterbury Ltd. A modem was installed in the F120 to facilitate remote access and programming changes to the fire panel, in addition to providing the ability to download reports to

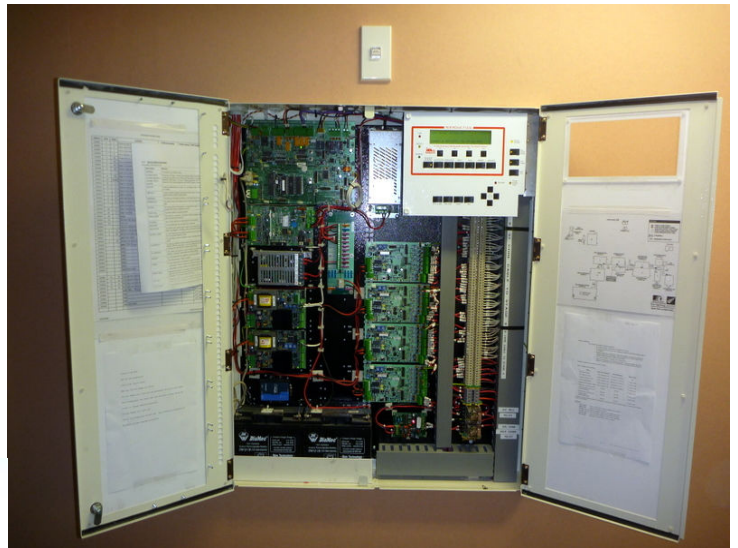

check on detector contamination levels and to review the historical events log (the modem is being replaced with an internet connection to provide a more robust and faster connection to and from Christchurch).

The wind turbines that can be seen on the left hand ridge in the photo on page one also have Vesda detectors mounted in their electrical equipment. While not connected back to the F120 panel, these Vesda detectors are interfaced to the Base's BMS system.

(Our thanks to FFP Canterbury for the information and images)

New In-Line Filter for Vesda Detectors

A new in-line filter for Vesda detectors has been released by Xtralis. It provides a convenient and cost-effective increase in the filtration of airborne contaminants for systems installed in a wide array of harsh environments, increasing the longevity of the system and reducing maintenance frequency as a result. The tapered design on the inlet and outlet connections simplifies installation to systems with either metric or imperial pipe diameters and, once installed, the filter element can be replaced without having to disconnect the filter from the pipework. More details are available on the Xtralis web site (accessed via the link on the Pertronic web site's home page).

