

PERTRONIC INDUSTRIES LTD

LED Display Unit (LDU) Installation Note: 12-Way / 8-Way



Overview

Pertronic Industries' **LED Display Unit (LDU)** is a Fire Alarm Panel Repeater / Mimic that allows the status of a Fire Alarm Panel to be displayed remotely by LED's.

The **12-Way Smart LED Display Board** connects with **F100A**, **F120A**, **F16e**, and **F16** panels via the RS485 Mimic port.

The **8-Way LED Display Board** connects directly to the **12-Way Smart LED Display Board** or to previous **8-Way LED Display Boards**.

Four additional products are also available:

- The **RS485 LED Address Controller (LAC)** board. This can be used in place of the 12-Way Smart LED Display Board.
- An **LED Zone Off-Set Board**. This can be used in conjunction with the 12-Way Smart LED Display Board to offset the start address of the LED's.
- The **8-Way Display Relay Extender Board**. This contains 8 non-latching relays that correspond to LED position numbers in the display.
- The **48-Way Open-Collector Board**. This provides a cost effective solution to control large numbers of LED's and/or Relays.

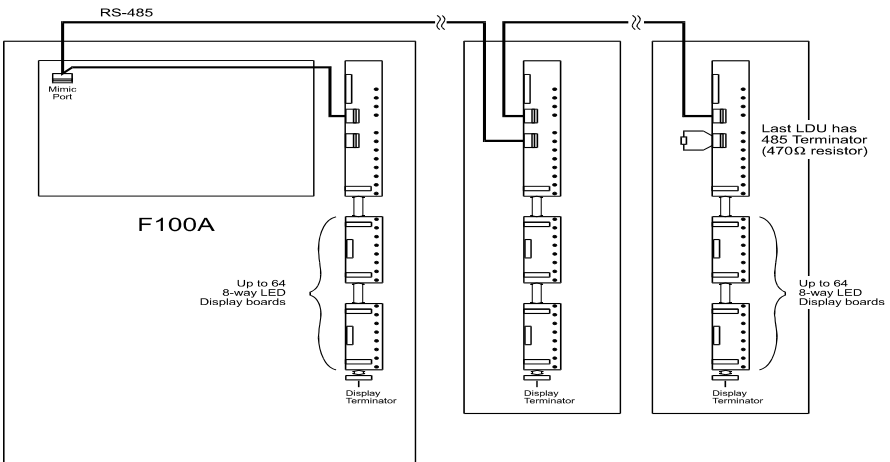

Connection to Panel

Three connectors are provided: K1 and K8, which use screw terminals; and K4 that uses an IDC connection. These connectors are provided to aid the connection of multiple LDU's or other RS485 devices.

Connections are: '+' 12 V to 24 V supply. Maximum current to LDU is 500 mA.
'0' Supply return.
A / B RS485 signal lines.

Twisted pair cable is recommended. The maximum length of cable between the last device on the Mimic Port and the Panel is 1.2km.

The A/B signal lines must be terminated at the remote device with a 470Ω resistor placed between A and B.

12-Way and 8-Way LDU Layout and Connection

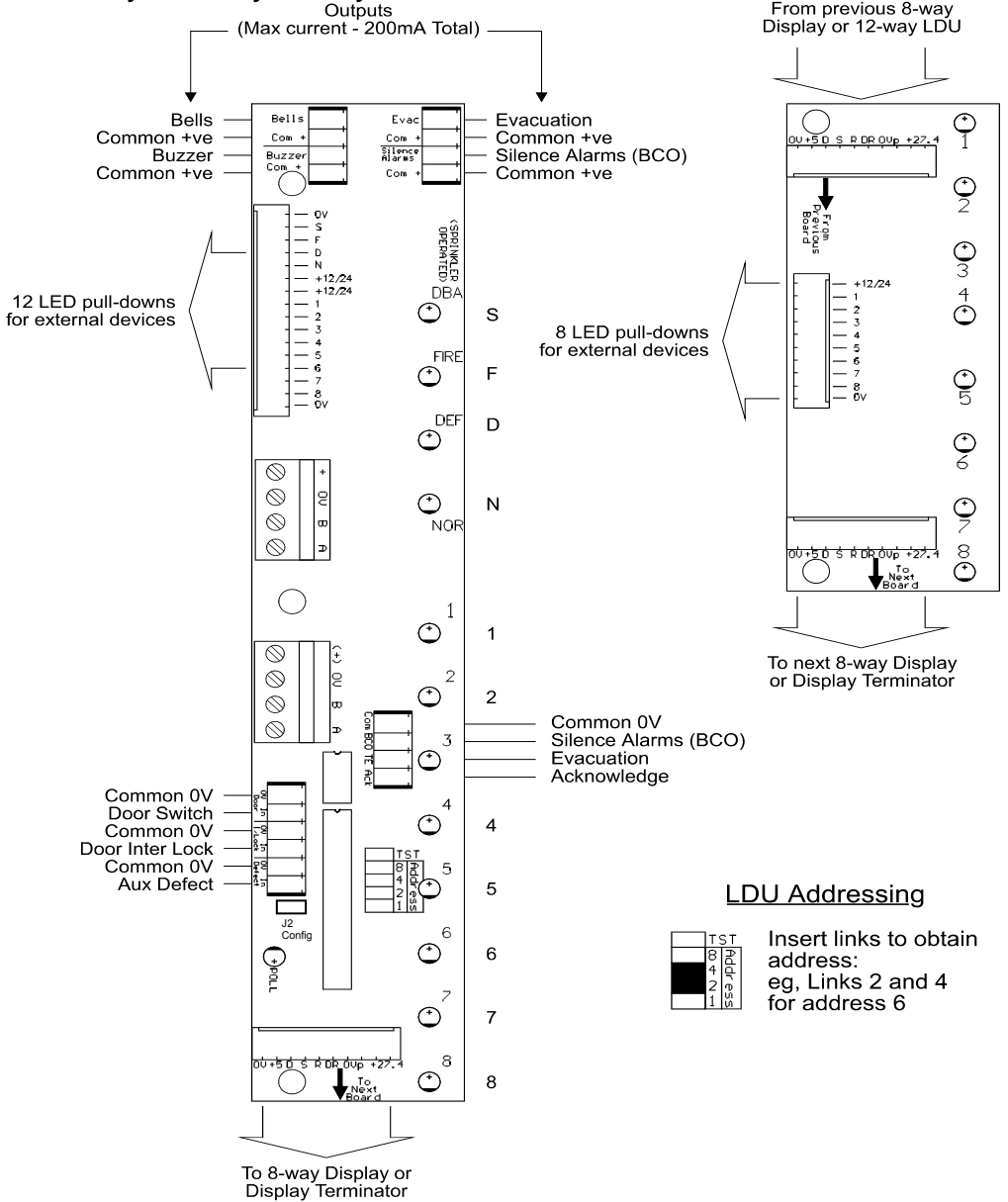

5-Way or 8-Way LED Operation

For Hardware 2.02 and Software ≥4.06, insert the J2 link for 5-way operation.

Mimics and LED Limits

Up to 32 x RS485 devices (LDU's, LCD Mimics, GPIB's, and such) may be connected to the RS485 line.

Up to 64 x **8-Way Display Boards** may be connected to the **12-Way Display Board**, giving a total of 520 LED indications for zones, plus the 4 global LED's, which are Sprinkler, Fire, Defect, and Normal. The **8-Way Display Boards** connect to the **12-Way Display Board** via the 10-Way IDC connector, K2.

The **F100A** can control up to 255 LED addresses; the **F120's** 512 LED addresses and the **F16e/F16** can control up to a maximum of 32 LED addresses. Note that in Residential mode the **F16e** may control a maximum of 64 LED's, 32 for Local (Residential) alarm and 32 for Global alarms.

LDU Addressing

Analogue Addressable Panels

Addresses 1 to 8 provide fully addressable boards, polled for input control information. These outputs pulse, and should be used for LED's. Address 9 is similar to addresses 1-8, except the inputs are not monitored; use for slave LDU's.

Address 10 is identical to address 9 except the outputs do not pulse; use for relay outputs. Addresses 11-15 are similar to addresses 1-5, except the outputs do not pulse; use with monitored inputs and steady outputs (relays). Any number of slave LDU's may be used, with the total number of devices on the **MIMIC** port limited to 32.

Conventional Panels

Addresses 1 to 3 are used for individually addressable boards, which are polled for input control information.

The panel must also be configured for the precise number of polled LDU's; otherwise, the panel reports a fault condition.

Fault Latches

4 fault conditions are detected and latched by the LDU. These are door interlock, LED chain fault, e2prom memory fault, and fire panel communication fault. The faults are latched and encoded by the **POLL/FAULT LATCH LED** when a fault is present. The latched states are reset when the power to the mimic is cycled off and on again.

1st flash long	Door Interlock
2nd flash long	LED Chain fault
3rd flash long	e2prom fault
4th flash long	Communication fault

Display Relay Boards

Display Relay Boards may be inserted anywhere in the chain of **LED Display boards** and **Relay Display Boards**, provided only version 2 or greater boards of both types are used.

NOTE: If version 1 LED or Relay boards are used, the version 2 LED or Relay boards must be placed at the end of the PCB chain.

LED Outputs (K3)

Each of the LED's of the 12-Way LDU and 8-Way LDU have drive capability for ancillary purposes. Each LED can sink 20mA to 0V via a diode and a 1k2Ω resistor—refer to the diagram. The LED's flash when active at a rate of 400ms ON, 400ms OFF. Note that the LEDs also flash when the LDU is being tested via the panel LED test function—the test has a different flash rate.

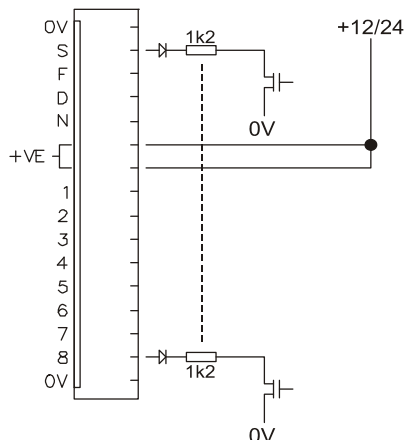

Output Functions (K6 and K9)

Four outputs are provided on the 12-Way LDU that follow the state of the corresponding panel signals:

- Buzzer** Activates (to 0V) when the panel internal Buzzer is ON. It may be silenced by signaling Acknowledge on K5 (refer to Input Functions).
- Bells** Activates when one or both of the panel Bell Relays are ON.
- Evacuation** Activates when any 'Evacuation' input is ON.
- Silence Alarms** Activates when any 'Silence Alarms' input on the system is ON.

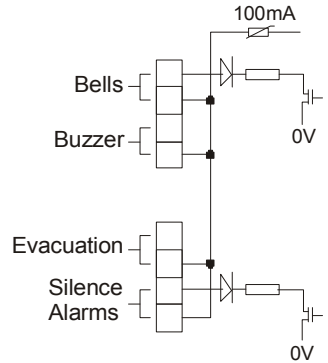

Input Functions (K5)

The input state of the function is sent to the fire panel if the LDU has an address 1 to 8. The active state occurs when the input function is connected to the Common (pin1):

- Silence Alarms (BCO)** Sent to the fire panel to silence the system alarms.
- Evacuation** Sent to the panel to activate the system alarms.
- Acknowledge** Sent to the panel to indicate a request to silence the buzzer.

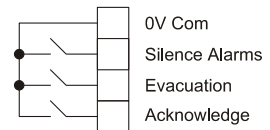

Connect input to Common to activate function

Auxiliary Functions (K7)

The input state of the function is sent to the fire panel if the LDU has an address 1 to 8. The active state occurs when the input is disconnected from the adjacent common:

- Door** Sent to the fire panel to indicate that the door switch (if connected) is open.
- Door Interlock** If the door interlock input is active, a door interlock signal is sent to the panel.
- External Defect** Sent to the panel in the event of a fault from an external device.

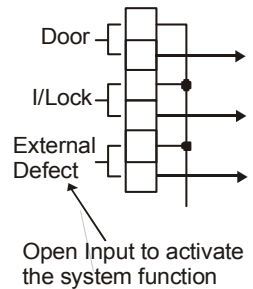

Display Terminator (K2)

A display terminator is required on the last device in the chain. This gives a return monitor signal by connecting pins 3 and 6 of the display bus.

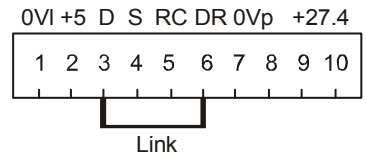

Product Codes:

Description	Product Code
12-Way Smart LED Display Board	F100PDB12
8-Way LED Display Extender Board	F100PDB
8-Way Display Relay Extender Board	F100ZDRLY
RS485 LED Address Controller (LAC)	LAC485
LED Address Controller (LED Offset) Board	LAC12W