

# Stopper® II Heated Enclosure

## STI-1200A-HTR

## STI-1200A-HTR240



## INSTALLATION INSTRUCTIONS

### Features:

- Maintains initiating device temperature with external temperatures to -70°F (-57°C). Independently tested to -102°F (-73°C).
- Protects initiating devices for addressable units to UL 38 Standards.
- The clear, protective polycarbonate cover is UV-stabilized against discoloration.
- Enclosure rated to NEMA 3R Standards to provide a degree of protection against rain, sleet, and damage from external ice formation.
- Fan runs continuously to maintain a uniform temperature inside the enclosure.
- Heater units cycle as required to maintain the correct range of operating temperatures.
- Polycarbonate backed by a lifetime warranty against breakage in normal use, one year on electrical parts.
- UL/ULC Listing does not require standby or secondary power for 110 or 240 VAC 50/60 Hz heater.



**Safety Technology International, Inc.**

*"We Protect The Things That Protect You."*

## Warnings and Installation Notes

The enclosure is used to protect UL Listed 38 and 2017 initiating devices at temperatures down to -70°F (-57°C). It is the installer's responsibility to comply with NEC 70 Articles 725 and 760, NFPA 72, and other applicable fire and electrical codes. Conduit or raceway paths need to be sealed as near to the enclosure as possible. Installer should have maintained supervision over the low temperature thermostat. The low temperature monitoring thermostat makes the circuit at +32°F (0°C) and clears the circuit at +50°F (+10°C). This listing requires that the fire alarm supervisory control module be only of the latching type. On the appliance mounting plate is a label where you should record the installation date. Also include below the serial number and installation date on the instruction sheet for quick reference.

Serial Number \_\_\_\_\_ Installation Date \_\_\_\_\_

**NOTE:** Operating voltage for the STI-1200A-HTR is 110 VAC. Operating voltage for the STI-1200A-HTR240 is 240 VAC.

1. Use of an outdoor rated initiating station is required with this heated enclosure.
2. When conducting periodic testing, if conditions are dusty or if you have wind blown dust conditions, cover return grill ports to minimize entrance of dust or sand particles. To remove accumulated dust or sand particles, use small containers of compressed air that is used for electronic cleaning.
3. To reset the thermal circuit breaker push button.  
If circuit breaker will not remain in a restored or closed position, conduct an electrical check of the various components in the two voltage classes. The two voltage classes are 24 VDC Negative Ground and 110 or 240 VAC 50-60 Hz with connected electrical or earth ground. High voltage (110 or 240 VAC) wiring must enter through bottom conduit. Low voltage and signaling wires must enter through top conduit and remain separated per NFPA 70, NEC, and local codes.
4. If the thermal circuit breaker has tripped (opened circuit), the 110 or 240 VAC 50-60 Hz power will still be energized up to the primary side of the thermal breaker. For safety, disconnect supply power of conductors to three power circuits in the enclosure.
5. To clean 24 VDC negative ground fan with electronic compressed air container, disconnect all power.  
**Note:** the 24 VDC negative ground fan will not operate if positive and negative conductors are connected on the wrong terminals.
6. To minimize arid summer time heat build up in enclosure, install a dark color sun shield with sides to provide shade for the enclosure. At the inclined face above the enclosure at the point of contact with the building structure leave at least 1/2" or (1.25 cm) space. This will generate heat and cause an upward airflow and help maintain the enclosure temperature approximately the same as ambient air temperature.
7. The 110 or 240 VAC single phase 50-60 Hz heater does not require standby or secondary power because the enclosure environment is supervised by a latching supervisory circuit in the alarm control unit or panel.
8. Replacement of heater assembly and gasket is required five years from installation date. Contact STI to order replacement Heater Kit STI-HK3.
9. All field wiring within this enclosure must be rated for a minimum operating range of 0°C - 110°C.

## Polycarbonate Cleaning Instructions

Rinse with water to remove abrasive dust and dirt. Wash with soap or mild detergent, using a soft cloth. Rinse once more, then dry with a soft cloth or chamois. Exercise caution when using water inside enclosure. Make sure unit is completely dry inside before reassembling. Do not use razor blades.

## Specifications

### Polycarbonate Enclosure:

Flammability:	UL94 V-2
Wall Thickness:	backbox: .20 inches (5.1mm) cover: .12 inches (3.1mm)
NEMA Rating:	3R
Warranty:	Lifetime against breakage in normal use.

### Silicone Laminate Heater:

STI-1200A-HTR 110 VAC 50/60 Hz	UL Recognized Component
STI-1200-A-HTR240 240 VAC 50/60 Hz	UL Recognized Component
100 Watts	
Life: @ -10°C (14°F) ~ 70°C (158°F)	5 Years
Duty Cycle: -40°F (-40°C)	16%
-70°F (-57°C)	38%
-99°F (-73°C)	100%

### Fan:

24 VDC (±10%), 90 mA	UL Recognized Component
Life:	5 Years Continuous Duty
⚠ WARNING: The polarity of the circulating fan is important as it only rotates in one direction with red lead being positive.	

### Gasket:

Material:	Neoprene
Life:	5 Years

## Installation Instructions

### Mount Enclosure Backbox - Refer to Fig 1

1. Set heater assembly with cover aside. Press (4) plastic tabs into slots on backbox and drill (4) 1/4" (6.4mm) diameter holes in mounting surface for plastic anchors provided. Attach backbox to wall using (4) #10 x 1-1/2" screws provided.

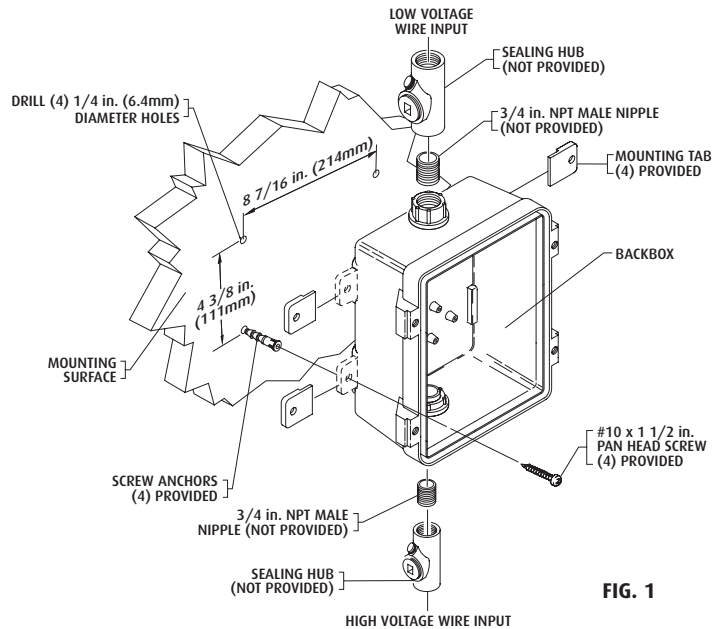

FIG. 1

2. Attach 3/4" rigid conduit and conduit sealing hub (Crouse-Hinds 3/4" EYSX 21 or equivalent) to backbox. Conduit should be installed according to applicable NEC and local codes.
3. Pull 24 VDC and alarm wiring into backbox through top conduit; and pull 110 or 240 VAC wiring into backbox through bottom conduit per NFPA 70, NEC and local codes.

**Note:** Wire size to be 12-22 AWG.

### Install Fire Alarm Pull Station and Dual Monitor Module to Heater and Cover Assembly - Refer to Fig 2.

4. Lift the cover from heater assembly and allow it to hang from cables. Connect the provided high temperature wires to the pull station.
5. Attach the pull station to the slide plate using (2) #6-32 x 3/8" screws provided. Adjust the slide plate so the pull station or slide plate does not cover either the fan opening or vent slots.

**Note:** If the fan opening or vent slots are covered, the plate mounting screws can be moved to the alternate mounting position. After mounting pull station adjust the slide plate so there are no gaps large enough to touch the heaters behind the pull station.

6. Turn assembly over and mount dual monitor module to the backside of the heater assembly using (4) #6-32 x 1" screws and (4) 3/8" standoffs provided. Replace cover.

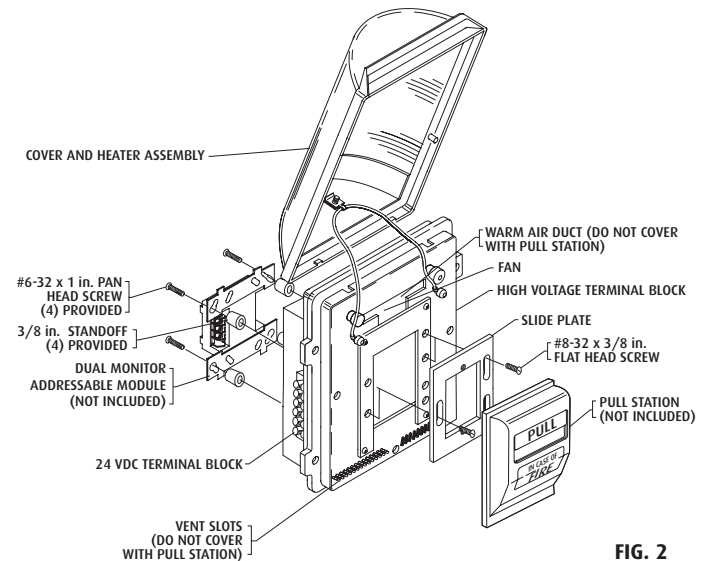

FIG. 2

### Wiring

7. Wire one channel of the dual monitor module to the low temp warning terminals (pins 1 & 2) on the 24 VDC terminal block. Wire the other channel to the fire alarm terminals (pins 5 & 6) on the same terminal block. Add any end of the line devices as required for the alarm system.
8. Connect wires from alarm panel to the dual monitor module according to design specifications. Connect continuous 24 VDC supply to fan power terminals (pins 3 & 4) of the 24 VDC terminal block.

#### **Note:**

1. Fan is polarity sensitive and must be connected correctly for fan to operate.
2. Fan operates continuously.
9. Connect the 110 or 240 VAC supply to the high voltage terminal block pins 4, 5, and 6. Earth Ground, AC Low, and AC High respectively.
10. Attach the heater and cover assembly to the backbox with (4) #8-32 x 3/4" socket cap screws and (4) #8 flat washers.
11. Record installation date in space provided on the label located on underside of cover. Unit is ready for testing.
12. Turn all power to "ON" position.

**Note:** Fan runs continuously. This system requires three sources of power:

1. 110 or 240 VAC heater on the load side of the fuse holder.
2. 24 VDC power source for the circulating fan. Check fan to see if operating; if not check polarity and reverse, then try again.
3. Fire alarm initiating circuit and temperature warning monitor.

# Product Assembly

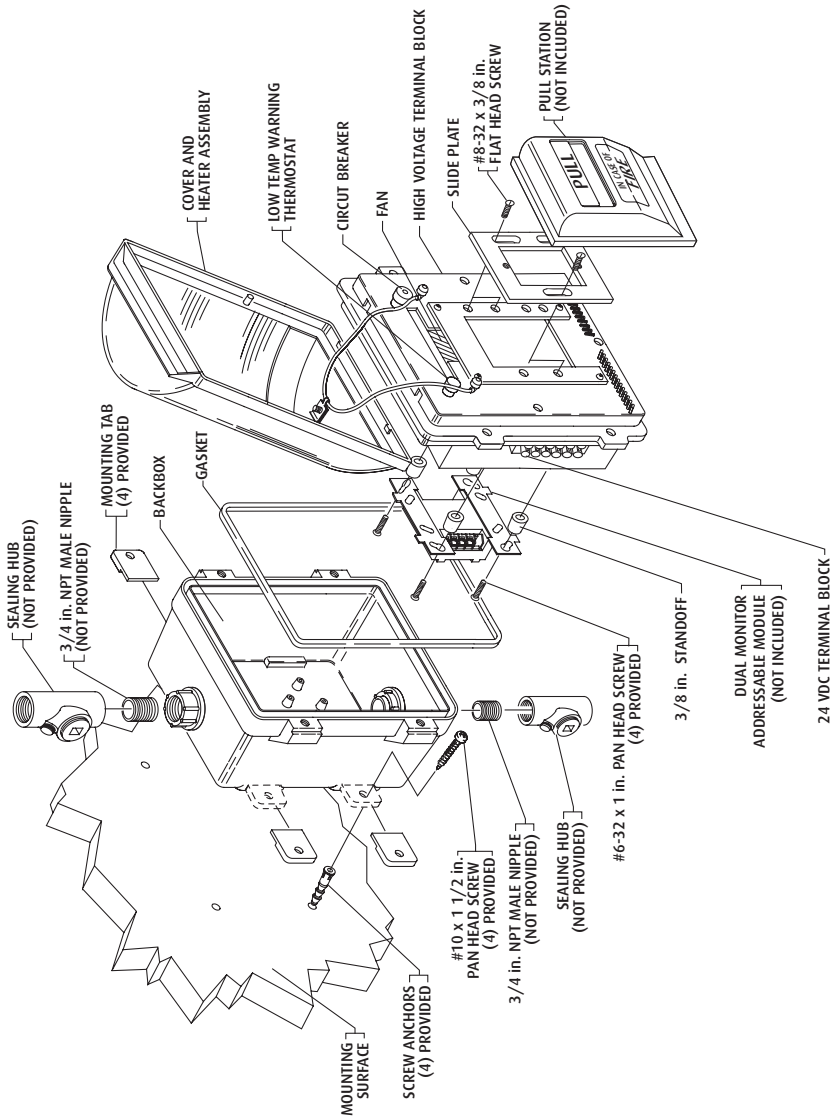

# Schematic Diagrams

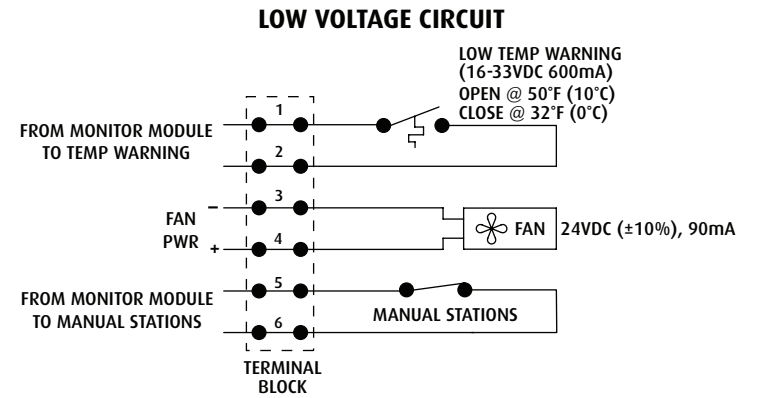
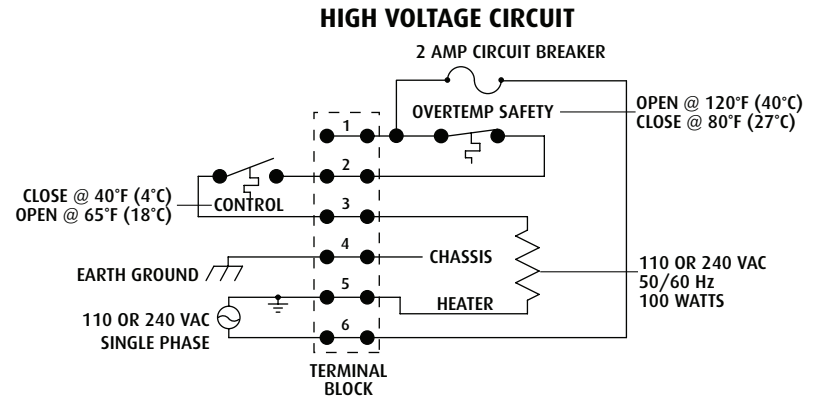



**Safety Technology International, Inc.**

2306 Airport Road  
Waterford, Michigan 48327-1209  
Phone: 248-673-9898 • Toll Free: 800-888-4784 • Fax: 248-673-1246

**[www.sti-usa.com](http://www.sti-usa.com)**

**Safety Technology International (Europe) Ltd.**

Unit 49G Pipers Road • Park Farm Industrial Estate • Redditch  
Worcestershire • B98 0HU • England • Tel: 44 (0) 1527 520 999  
Fax: 44 (0) 1527 501 999 • Freephone: 0800 085 1678 (UK only)  
E-mail: [info@sti-europe.com](mailto:info@sti-europe.com) • Web: [www.sti-europe.com](http://www.sti-europe.com)