



3825 Ohio Avenue, St. Charles, Illinois 60174
800/736-7672, FAX: 630/377-6495
www.systemsensor.com

BEAM1224, BEAM1224S
Single-ended Reflected Type
Projected Beam Smoke Detector

Specifications

General

Range:	16 to 230 Feet (5 to 70m) 230 to 328 Feet (70 to 100m) using optional accessory BEAMLRK
Sensitivity:	25% to 50% Total Obscuration in 6 levels Level 1 = 25% Level 2 = 30% Level 3 = 40% Level 4 = 50% Level 5 = 30% to 50% (Acclimate) Level 6 = 40% to 50% (Acclimate)
Spacing:	30 to 60 Feet (9.1 to 18.3 m)
Response Time:	Alarm: 20 seconds typical Trouble: 30 seconds typical
Trouble Conditions:	Beam Blockage (96% or More Obscuration) Improper Initial Alignment Self-compensation limit reached (service needed) In Alignment mode
Test/Reset Features:	Integral Sensitivity Test Filter (BEAM1224S only) Sensitivity Filter (Incremental scale on reflector) Local Alarm Test Switch Local Alarm Reset Switch Remote Test and Reset Switch Capability (compatible with RTS451/RTS451KEY)
Indicators:	Alarm: Remote Output, Local LED (red) Trouble: Remote Output, Local LED (yellow) Blink Pattern Indicates Trouble Diagnostics Normal Operation: Local LED (flashing green once every 5 sec) Alignment Aids: Optical Gunsight (coarse adjustment) 00 to 99 Digital Display (fine adjustment) Relays: Alarm; Trouble Sensitivity: Digital Display Readout in Percent Obscuration

Environmental

Temperature:	-22°F to 131°F (-30°C to 55°C) Note: For applications below 32°F (0°C), see Special Applications section of this manual
Humidity:	10% to 93% RH Noncondensing

Mechanical

Shipping Weight:	Complete unit: 3.9 lbs. (1.77 kg)
Shipping Size:	15" × 10.5" × 6.5" (381 mm × 267 mm × 165 mm)
Mounting:	Wall only without optional accessories
Wiring:	Plug-in Terminal Blocks (12 to 22AWG)
Adjustment Angle:	± 10° Horizontal and Vertical
Paintable Trim Ring:	May be painted using enamel or acrylic type paints

Electrical

Voltage:	10.2 to 32 VDC (BEAM1224) 15 to 32 VDC (BEAM1224S)
Maximum Ripple Voltage:	6.0 volts (Peak-to-peak) Note: ripple must not fall below minimum operating voltage specification
Current (24 VDC):	Avg. Standby: 17mA Max. Avg. Alarm: 38.5mA Max. Avg. Trouble: 8.5mA Max. Avg. Alignment: 28mA Max.
Current (Test Mode) (BEAM1224S only):	Peak Test: 500mA Max.
Relay Contacts:	0.5A at 30 VDC
Reset Time:	0.3 Seconds Max.
Start-up Time (after 2min. reset):	60 sec Max.
Alarm Verification Time:	5 sec Max.
Remote Output: (Alarm & Trouble)	Voltage: 15 to 32VDC Note: Output voltage same as device input voltage. Current: 15mA maximum 6mA minimum Note: Output current is limited by 2.2Kohm resistor

Before Installing

Please thoroughly read this manual and applicable sections of System Sensor's Projected Beam Detector Application Guide. Copies of this manual are available from System Sensor.

General Description

System Sensor Model BEAM1224/BEAM1224S is a long range projected beam smoke detector designed to provide open area protection. It is to be used with UL-listed, separately supplied power (4-wire) control panels only. The detector consists of a transmitter/receiver unit and a reflector. Smoke entering the area between the transmitter/receiver and reflector causes a reduction in signal. When the obscuration reaches alarm thresholds (chosen at the transmitter/receiver unit), the detector generates an alarm signal. Complete blockage of the beam causes a trouble signal. Slow changes in obscuration due to a build up of dirt or dust on the lens of the detector are compensated for by a microcontroller that continuously monitors the signal strength and periodically updates the alarm and trouble thresholds. When the self-compensation circuit reaches its limit, the detector generates a trouble signal, indicating the need for service.

Three LEDs on the detector indicate the current status: a red LED for alarm, a yellow LED for trouble, and a blinking green LED for standby operation. The alarm signal latches and can be reset by a momentary power interruption, by using the remote reset input to the detector if using the remote test/reset station model RTS451, or with the local reset button located on the detector. The local reset button is accessible by removing the outer paintable trim ring. The yellow LED will blink in specific patterns to provide a

diagnostic aid when diagnosing the cause of a trouble signal. Trouble signals automatically reset upon removing the cause of trouble. In addition to these indicators, there is a dual digital display that reads 00 to 99. This display is used to indicate the signal strength of the beam in alignment mode and to indicate the sensitivity setting of the detector in percent obscuration when setting the sensitivity of the detector. No additional equipment is needed for alignment of the beam.

Each detector contains one Form A (normally open) contact for alarm signals and one Form B (normally closed) contact for trouble signals. The trouble contact will open if power is removed from the detector. Thus, an additional EOL power supervision relay is not necessary. The trouble contacts from all the beam detectors on one initiating circuit must be connected after the last indicating device on the loop. This prevents a single beam detector in trouble from disabling other initiating devices on the same loop.

Special Applications

Due to the inherent capabilities of projected type beam detectors they are often installed in locations where spot-type detection is impractical. Projected type beam smoke detectors are ideally suited for environmental conditions that might include high ceilings, dusty and dirty environments, or environments that experience temperature extremes. Often these conditions present special problems for the installation of spot-type detectors and even greater problems for their proper maintenance. Due to the inherent flexibility of mounting locations and large coverage area of projected type beam detectors often the conditions above can be addressed or minimized.

Some examples of applications for beam detectors might include freezers, aircraft hangars, cold storage warehouses, shipping warehouses, enclosed parking facilities, sporting arenas and stadiums, concert halls, barns, or stables. Some of these environments might be considered to hostile for spot-type smoke detectors. If the environment is considered to be hostile then the colder alarm threshold settings should be used.

Before installing the transmitter/receiver unit or reflector in these types of applications special consideration should be given to insure proper operation of the beam detector. The beam detector should not be installed in environments where there is no temperature control and condensation or icing is likely. Condensation or icing of the reflector surface or the outer surface of the transmitter/receiver unit will obscure the light beam resulting in a false alarm. If elevated humidity levels and rapidly changing temperatures can be expected then condensation will likely form and the application should not be considered acceptable for the beam detector. The beam detector should not be installed in locations where the transmitter/receiver unit, the reflector, or the optical pathway between them may be exposed to outdoor conditions such as rain, snow, sleet, or fog. These conditions will impair the proper operation of the detector and must be avoided.

Approved Accessories

The following accessories can be purchased separately for use with this beam detector.

BEAMLRK

The BEAMLRK allows System Sensor reflected beam detectors to be installed at separations between 230 and 328 feet (70 to 100 meters). At these distances, four 8"×8" reflectors must be used to provide enough reflected infrared light. This kit includes 3 additional reflectors with new test scale legends. The reflector included with the transmitter/receiver unit is the fourth reflector to be used. This kit is not compatible with the multi-mount kit (BEAMMMK).

BEAMMMK

The BEAMMMK allows System Sensor reflected beam detectors and reflectors to be mounted to either a vertical wall or the ceiling. The kit allows for additional alignment range in cases where the detector and reflector cannot be mounted within 10° of each other. The kit includes the hardware necessary to mount either a single transmitter/receiver unit or a single reflector. (To mount the transmitter/receiver the surface mount kit, BEAMSMK, must also be used). If the transmitter/receiver and the reflector require additional alignment range two kits are required. The kit is not compatible with the long-range reflector kit (BEAMLRK).

BEAMSMK

The BEAMSMK allows System Sensor reflected beam detectors to be mounted when surface wiring is used. This kit must be used when mounting the transmitter/receiver unit with the multi-mount kit (BEAMMMK).

RTS451/KEY

The remote test accessory, RTS451/KEY allows for the beam detector to be tested remotely. The test accessory provides test and reset functions and green and red LED's that mimic the LED's on the detector.

Parts List

<u>Description</u>	<u>Quantity</u>
Transmitter/Receiver Unit	1
Paintable Trim Ring	1
Reflector	1
Plug-in Terminal Blocks	4
Instruction Manual	1
Orange Sticky Paper	1

Parts Diagram (not to scale)

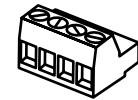

Terminal Block

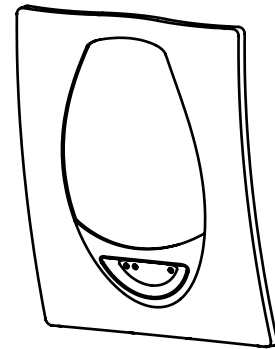

Paintable Trim Ring

C0306-00

Detector Placement

This section of the manual discusses the placement of projected beam detectors. Though this information is based upon industry expertise, it is intended to be used only as a technical guide. Always comply with the requirements of applicable codes and standards such as, NFPA 72, National Fire Alarm Code, as well as directives of the Authority Having Jurisdiction (AHJ). For general information on the placement of detectors, read System Sensor's Projected Beam Detector Application Guide.

Projected beam detectors are usually located with their beams parallel to the ceiling. However, they can be mounted vertically or at any angle to protect the area involved. Since beam detectors sense the smoke buildup over a distance, they are ideal for locations with high ceilings. They can also be mounted on a wall or ceiling below the level of a spot type detector, reducing the effects of air stratification. Some typical locations would include large areas with high ceilings such as atriums, warehouses, and factories.

NOTE: Projected beam smoke detectors should always be mounted to stable mounting surfaces. See the MOUNTING LOCATION section for details.

Some fire codes specify spacing on a given center-to-center distance between detectors under ideal conditions. This spacing is based on rooms with smooth ceilings and no physical obstructions between the contents being protected and the detectors. Moreover, they are also based on a maximum ceiling height, and on the assumption that the value and the combustible nature of the contents of the room being protected do not warrant greater protection or closer spacing.

In a room with a smooth ceiling, detectors should be spaced between 30 and 60 feet (9.1 to 18.3m). One-half that spacing between the beam and the sidewall may be used as a guide. See Figure 1. The beam detector can be mounted with the transmitter/receiver on one wall and the reflector on the opposite wall, or both suspended from the ceiling, or any wall/ceiling combination. In the case of the ceiling mount, the distance from the end walls should not exceed one-quarter of the selected spacing (7.5 ft. [2.3m] maximum if the spacing is 30 ft. [9.1m]). See Figure 2.

Figure 1. Spacing for smooth ceiling (side view):

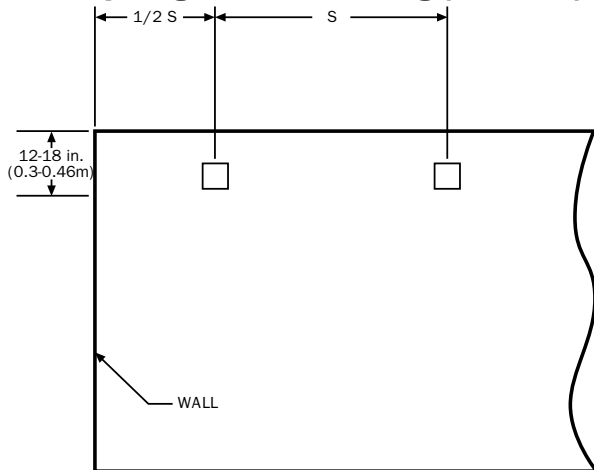

C0254-00

Figure 2. Spacing for smooth ceiling (top view):

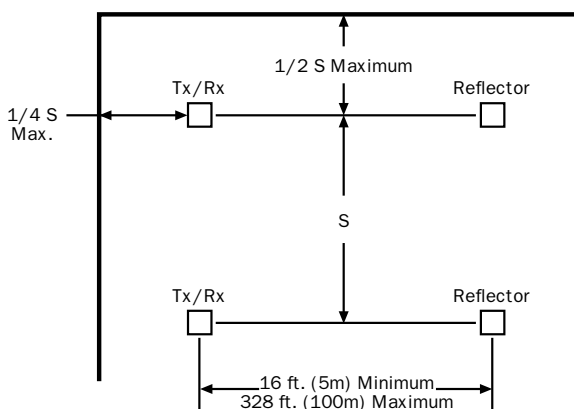

C0255-00

In the case of peaked or sloped ceilings, codes may specify spacing of detectors by using horizontal spacing from the peak of the roof or ceiling. Figures 3 and 4 show the spacing for both the shed type and peaked type sloped ceilings.

On smooth ceilings, beam smoke detectors should generally be mounted between 12 and 18 inches (0.3 to 0.46m) from the ceiling. In many cases, however, the location and sensitivity of the detectors shall be the result of an engineering evaluation that includes the following: structural features, size and shape of the room and bays, occupancy and uses of the area, ceiling height, ceiling shape, surface and obstructions, ventilation, ambient environment, burning characteristics of the combustible materials present, and the configuration of the contents in the area to be protected.

Figure 3. Sloped ceiling (shed type):

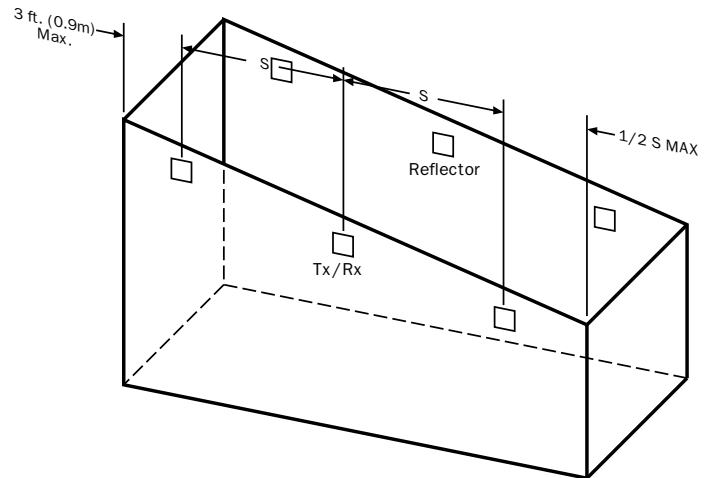

C0256-00

Figure 4. Sloped ceiling (peaked type):

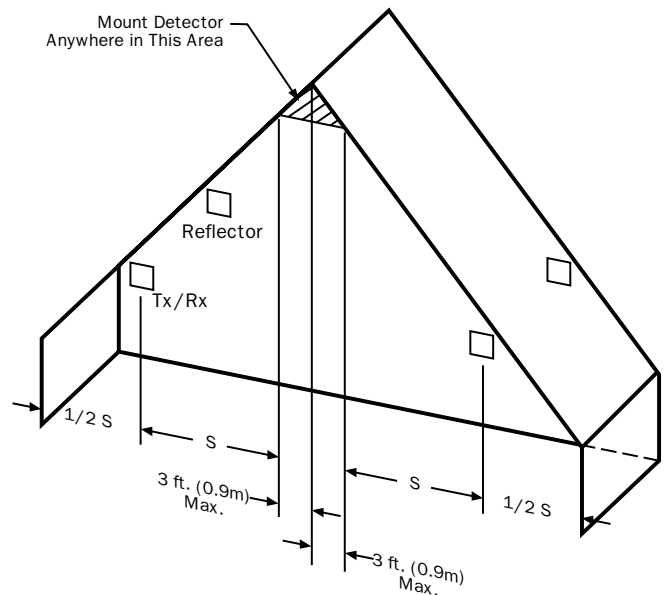

C0257-00

Mounting Locations

Beam detectors require a stable mounting surface for proper operation. A surface that moves, shifts, vibrates, or warps over time will cause false alarm or trouble conditions. Initial selection of a proper mounting surface will eliminate false alarms and nuisance trouble signals.

Mount the detector on a stable mounting surface, such as brick, concrete, a sturdy load-bearing wall, support column, structural beam, or other surface that is not expected to experience vibration or movement over time. DO NOT MOUNT the beam detector on corrugated metal walls, sheet metal walls, external building sheathing, external siding, suspended ceilings, steel web trusses, rafters, non-structural beam, joists, or other such surfaces.

In cases where only one stable mounting surface as defined above can be used, the transmitter/receiver unit should be mounted to the stable surface and the reflector should be mounted to the less stable surface. The reflector has a much greater tolerance for the unstable mounting locations defined above.

Mounting Instructions

The transmitter/receiver unit may be mounted over a recessed junction box. The cavity behind the detector is then used for routing of the wiring from the junction box to the terminal blocks on the detector. The transmitter/receiver unit should be mounted to the wall such that unit covers the recessed junction box in the wall completely. If the junction box is not recessed then you may use the surface mount kit (BEAMSMK). See the BEAMSMK installation instructions for surface mounting instructions. The transmitter/receiver unit can be mounted to the wall using the supplied drilling template (see Appendix II). The detector base has 4 primary mounting keyholes, one in each corner of the base. All four hole locations should be used to provide a secure mounting. The outer housing of the beam detector is held to the base using four screws. In order to mount the detector you must remove the outer housing first.

The reflector can be mounted to the wall using the supplied drilling template see (Appendix III). The reflector has 4 mounting holes, one in each corner. All four hole locations should be used to provide a secure mounting. The reflector must be mounted such that it is within 10° in both the X and Y planes of the transmitter/receiver unit. See Figure 5a. The reflector must also be mounted such that plane of the reflector is perpendicular to the optical line of sight to the transmitter/receiver unit. The maximum tolerance for non-perpendicular mounting locations is 10° . See Figure 5b. If the reflector cannot be mounted within 10° of the transmitter/receiver unit then the multi-mount kit (BEAMMMK) may be used to provide greater angular

adjustment of the transmitter/receiver unit. If the perpendicular plane of the reflector cannot be mounted within 10° of the optical line of sight then the multi-mount kit can be used for the reflector. See BEAMMMK instructions.

To aid in locating the reflector in the alignment mirror at long distances a bright orange sticky backed piece of paper is provided. Remove the protective backing from the orange sticker. Temporarily affix the orange paper next to the reflector using the sticky backing of the paper. The location of the sticky paper is not critical. It may be placed anywhere near the reflector as long as it not covering the reflective surface of the reflector. This sticky paper should be removed once the installation is completed.

Figure 5a. Reflector Mounting Guidelines

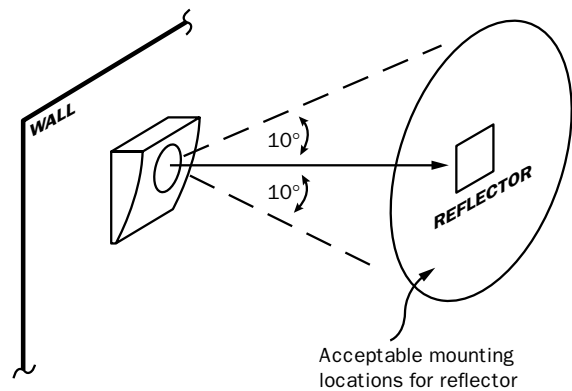

C0258-00

Figure 5b. Reflector Mounting Guidelines

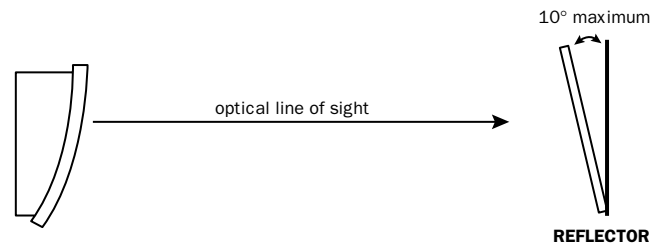

C0259-00

Mounting Considerations for Single Ended Beam Detectors

There must be a permanent clear line of vision between the detector and the reflector. Reflective objects must not be near the line of vision between the detector and reflector. Reflective objects too near to the line of sight can reflect the light beam from the transmitter to the receiver. If this occurs, the detector will not be able to distinguish these reflections from those of the reflector and the protected space will be compromised. Reflective objects should be a minimum of 4 feet (1.2m) from the line of sight between the detector and reflector. In cases where reflective objects cannot be avoided, the complete reflector blockage test can be used to determine if the installation is acceptable. See Testing and Maintenance Section of this manual.

Light sources of extreme intensity such as sunlight and halogen lamps, if directed at the receiver, can cause a dramatic signal change resulting in fault and alarm signals. To prevent this problem direct sunlight into the transmitter/receiver unit should be avoided. There should be a minimum of 10° between the pathway of the light source and detector and the line of sight between detector and reflector.

Operation of the detector through panes of glass should be avoided. Since single ended beam detectors operate on a reflection principle, a pane of glass perpendicular to the line of sight between the detector and the reflector can reflect the light beam from the transmitter to the receiver. If this occurs, the detector will not be able to distinguish these reflections from those of the reflector and the protected space will be compromised.

Panes of glass will also absorb some of the light as it passes through it. This absorption of light will reduce the acceptable installed distance between the detector and the reflector.

In cases where operation through panes of glass cannot be avoided some specific installation practices can help to minimize the effects of the glass. These practices include: avoid penetration of multiple panes of glass, position the glass so that it is not perpendicular to the line of sight between the detector and the reflector, (A minimum of 10° off perpendicular should be considered), and make certain that the glass is smooth, clear and mounted securely. The complete reflector blockage test can be used to determine if the installation is acceptable. See Testing and Maintenance Section of this manual.

Where high ceilings (in excess of 30 feet or 9.1 meters) are present additional beams may be required to detect smoke at lower levels. See System Sensor's Projected Beam Detector Applications Guide for further explanation.

Wiring Installation Guidelines

Always install all wiring in compliance with the National Electrical Code, and/or the applicable local codes, and any special requirements of the local authority having jurisdiction. Proper wire gauges and suitable means for strain relief should be used. The conductors used to connect beam smoke detectors to control panels and accessory devices should be color-coded to reduce the likelihood of wiring errors. Improper connections can prevent a system from responding properly in the event of a fire.

Installation wire used for the beam detector shall be no smaller than 22 AWG (1.0 mm²). For best system performance, all wiring should be twisted pair and installed in separate grounded conduit. Do NOT mix fire system wiring in the same conduit as any other electrical wiring. Shielded cable may be used to provide additional protection against electrical interference.

When installing the beam smoke detector in applications where the head unit will be mounted to either a wall or the ceiling using the multi-mount kit (BEAMMMK) flexible conduit will be used. The surface mount kit (BEAMSMK) and multi-mount kit (BEAMMMK) must be installed with the cable before wiring the unit, according to the instructions supplied with the kit.

When the detector has been mounted over a recessed junction box, all wiring should be routed out of the box and behind the detector to the bottom of the detector where the terminal blocks are located. When installing the wiring in the junction box be sure to leave enough wire in the box to connect to the terminal blocks. (Approximately 9" [23cm] of wire outside of the junction box will be required for proper installation). All wiring to the detector is done via pluggable terminal blocks. In order to properly make electrical connections strip approximately 1/4" (6mm) of insulation from the end of the wire, sliding the bare end of the wire under the clamping plate screw.

Figure 6 shows all the wiring connections to the transmitter/receiver unit. Figure 7 shows the proper wiring diagram for either class A or class B operation. Figure 8 shows the connections that are necessary when using one of the optional remote test stations (RTS451 or RTS451KEY). Figure 9 shows the remote outputs for trouble and alarm.

Figure 6. Wiring Connections at Detector

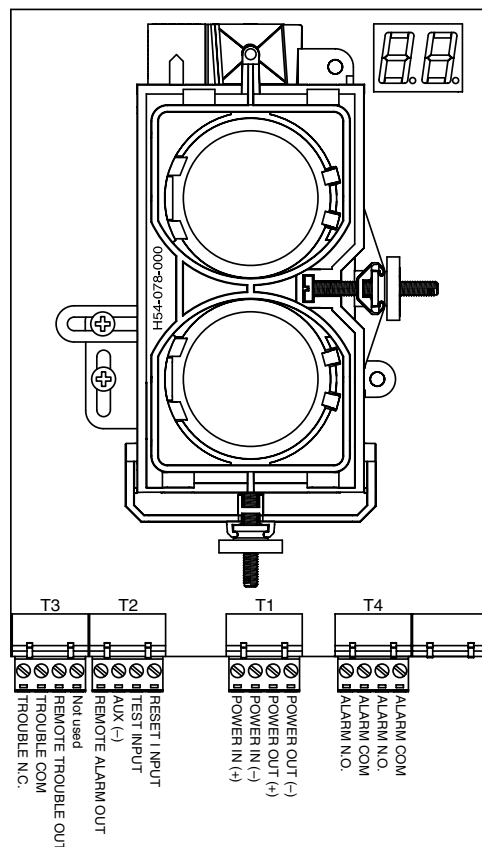

C0271-00

Figure 7. Wiring Diagram

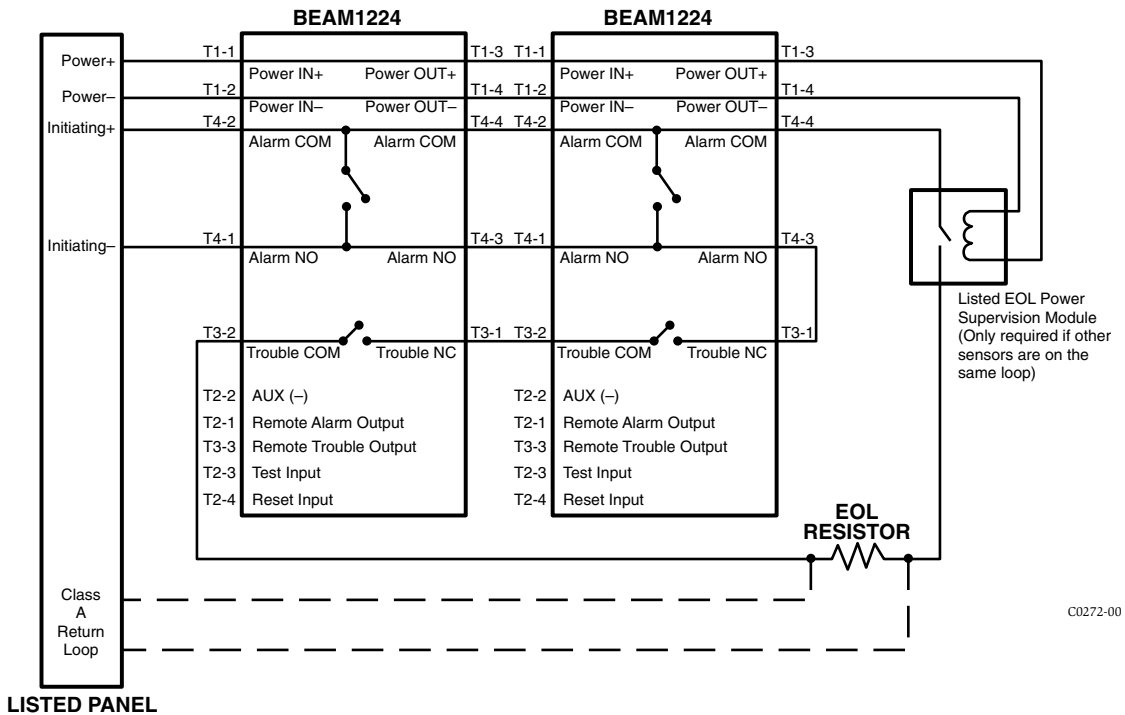
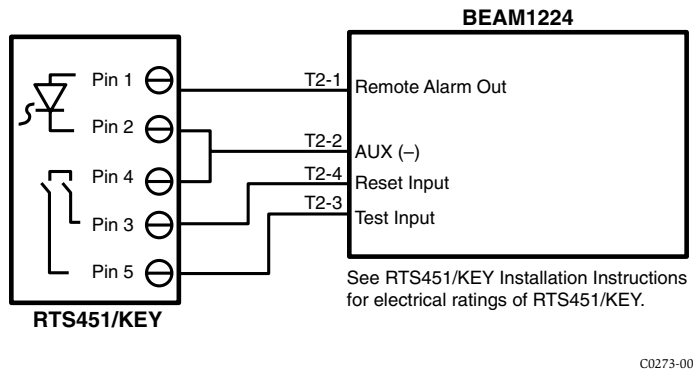

Figure 8. Wiring Diagram (RTS451)



WARNING: Disable the zone or system before applying power to the beam detector to prevent unwanted alarms. When applying power to the beam detector before the alignment procedure has been completed the detector may enter alarm or trouble.

Installation / Alignment

Reference Figures 10 through 14 for installation, alignment, and maintenance.

The alignment of the BEAM1224/BEAM1224S is divided into four steps: coarse alignment, fine adjustment, final gain adjustment, and final verification. It is necessary for all four steps to be executed properly to ensure proper alignment of the product. If the detector and reflector

Figure 9. Wiring Diagram (RTS451)

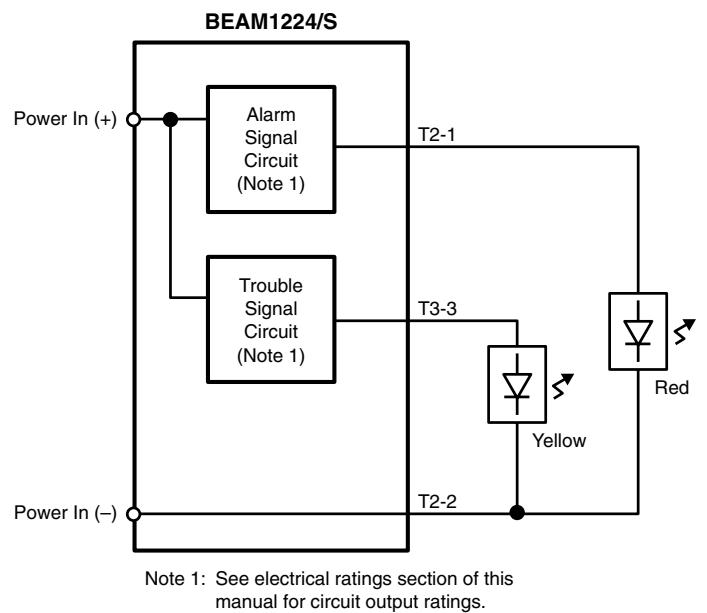

are mounted per Mounting Locations and Mounting Instructions sections of this manual and the alignment procedures are executed properly, false alarms and nuisance trouble signals will be minimized.

Pre-Alignment Checklist

- Insure that both the detector and reflector are mounted securely to stable surfaces.
- Insure that all wiring is correct.

- Insure that terminal blocks are fully seated into their receptacles on the detector.
- Complete any wiring dressing to minimize movement to the detector once the alignment procedure is completed.
- Insure that the appropriate number of reflectors are used for the installed distance. Distances between 230 & 328 Feet (70 - 100m) require additional reflectors (4 total). The BEAMLRK accessory should be used in these cases.
- Insure that the line of sight between the detector and reflector is clear and that reflective objects are not too near. See mounting Instructions for more details.
- Insure that both the detector and reflector are mounted within their operational parameters for off axis angles. See Mounting Instructions for more details.
- Disable the zone or system to prevent unwanted alarms before applying power.
- Insure power to the detector is “ON”.

You are now ready to begin the alignment procedure.

Step 1. Coarse Alignment

Refer to Figures 11 and 12 for this step.

1. Insure that both of the optics lock-down screws are loosened so that the optics will move feely.
2. Looking through the alignment mirror at both the alignment sight and reflector simultaneously locate the position of the reflector in the optical sight. This step will require some practice. It is necessary to train your eyes to shift focus between the reflector and the mirror in order to locate the reflector. If the distance between the reflector and the detector is large it is helpful to place a brightly colored object on the wall near the reflector to aide in seeing the reflector in the alignment mirror.
3. Once the reflector has been located, begin to adjust both the horizontal and vertical alignment knobs so that the reflector becomes centered in the alignment mirror. Take care in this step. If the optics are incorrectly aligned in this step, it will not be possible to proceed with the fine adjustment step.

Step 2. Fine Adjustment

Refer to figures 10 through 12 for this step.

In this step you will be fine-tuning the optics to the reflector. To provide feedback of the signal level coming from the reflector the dual digital display readout will be used. Due to the large distance range that the detector can operate over it is necessary that the detector operate with many different settings of “electronic amplifier gain”. The detector is capable of determining the appropriate gain setting and then setting it itself via on-board processing algorithms. There are no external gain settings on the detector that

must be set by the operator. Periodically throughout the fine adjustment step the detector will need to re-adjust its “electronic amplifier gain” setting. When this occurs it will be indicated by the dual digital readout as “- -”. When this occurs, cease any further adjustment until the display again reads a number value.

1. Insure that neither you nor any other objects are in the line of sight between the detector and the reflector.
2. Depress the Alignment switch once. Both the digital display and the yellow LED should turn on indicating that alignment mode has been entered. The display should begin reading “- -” signifying an electronic gain adjustment. After a few moments the display will indicate a numeric value near 20. If the display reads “Lo” then the detector is not receiving enough light from the reflector. Go back and repeat the coarse alignment step and verify that the proper number of reflectors is used for the installed distance.

Note: The display will continue to read “Lo” until the detector receives enough light from the reflector to continue with the fine adjustment step.

Note: In alignment mode (indicated by the yellow LED and the numeric display) the sensitivity select and test switches are disabled.

3. With the display reading a numeric value, begin adjusting the horizontal and vertical alignment knobs one at a time in the direction that increases the numeric signal level on the display. Continue adjusting each axis one at a time going back and forth between them until a peak value is indicated. If a value of 90 is achieved, the detector will re-adjust the electronic gain once again. This will be indicated by a “- -” reading on the display. When this happens halt any further adjustment until the display again reads a numeric value. This process may occur more than once during the fine adjustment step.

Note: Each time the display reads a value of 90 or greater the detector will reduce the electronic gain. Each time the display reads a value of 10 or less the detector will increase the electronic gain.

4. Once satisfied that it is not possible to achieve a higher reading on the display, depress the alignment switch to complete the fine adjustment step. The digital display readout will turn “OFF” and the yellow LED will remain “ON”.

Note: It may not be possible to achieve a value near 90 on the display during the last adjustment iteration. The

final value of the display will not likely be near 90. This is normal. It is due to the detector reducing its electronic gain each time a value of 90 is achieved. When this occurs the detector resumes with less electronic gain than previously when 90 was achieved. Less gain makes it more difficult to achieve higher values. Final values anywhere between 20 and 90 are acceptable if no further increase can be achieved.

Note: The alignment procedure is not complete yet.

At this time it is possible to set the sensitivity of the detector using the sensitivity switch and digital display. See the Sensitivity Selection section of this manual for further details.

Step 3. Final Gain Adjustment

Refer to Figure 13 for this step.

In this step, the detector will electronically adjust its internal gain one final time. It is necessary to complete this step with the outer housing installed since the housing will change the amount of light received from the reflector.

1. Install the outer housing of the detector. The housing is installed by tightening four screws, one in each corner of the housing. The screws are captivated in the plastic of the housing and cannot fall out during assembly.
2. Remove the protective film from the front surface of the outer housing.

Note: The housing contains a gasket seal that protects the detector circuitry from corrosion and moisture sources. To insure that the gasket seal performs correctly it is necessary to fully tighten all four of the screws that hold the outer housing in place.

3. To initiate the final electronic gain adjustment, the reset switch must be depressed. Once depressed the yellow LED will begin to blink. This indicates that the detector is adjusting the electronic gain setting. Once complete, the yellow LED will stop blinking and the green LED will begin blinking. This indicates that the gain adjustment was successful.

Note: Use caution not to block the line of sight between the detector and reflector in this step.

4. Install the outer aesthetic ring by snapping it onto the outer housing.

Note: If the outer aesthetic ring has been painted insure that the paint is completely dry before proceeding with this step.

Step 4. Final Verification

This step is required to insure the detector has been setup correctly and will detect smoke at the proper sensitivity level.

1. With the detector functioning (indicated by the green LED blinking), completely block the reflector with an opaque material. (Due to the high optical efficiency of the reflector the selection of the opaque material used to block the reflector is not critical. Acceptable materials include, but aren't limited to, this manual or the cardboard packaging inserts.) See Figure 14. The detector should enter the trouble condition (indicated by the fault relay and the yellow LED (see Appendix I). If the detector does not enter the trouble condition there is a problem with the installation refer to the troubleshoot section in Appendix I for further assistance.
2. Complete a sensitivity test of the detector. Refer to the Sensitivity Testing section of this manual for the appropriate procedure.
3. If the orange sticky paper was used to aid in the location of the reflector in the alignment mirror it should be removed now. It is no longer necessary.

Congratulations. You have completed the final installation and alignment procedure.

Figure 10. Switch Locations

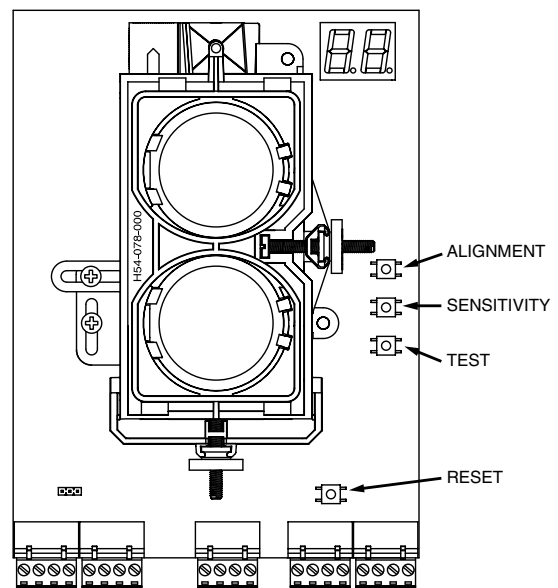

C0274-00

Figure 11. Alignment Adjustment Locations

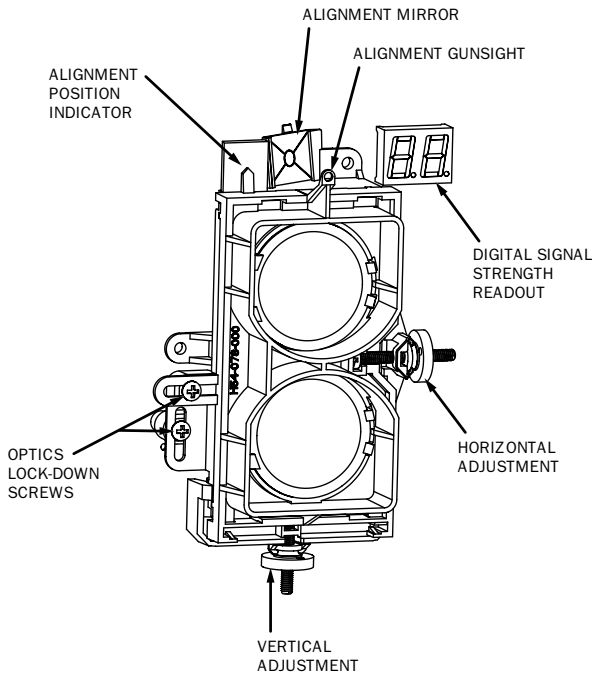

C0264-00

Figure 13. Housing Screw Locations

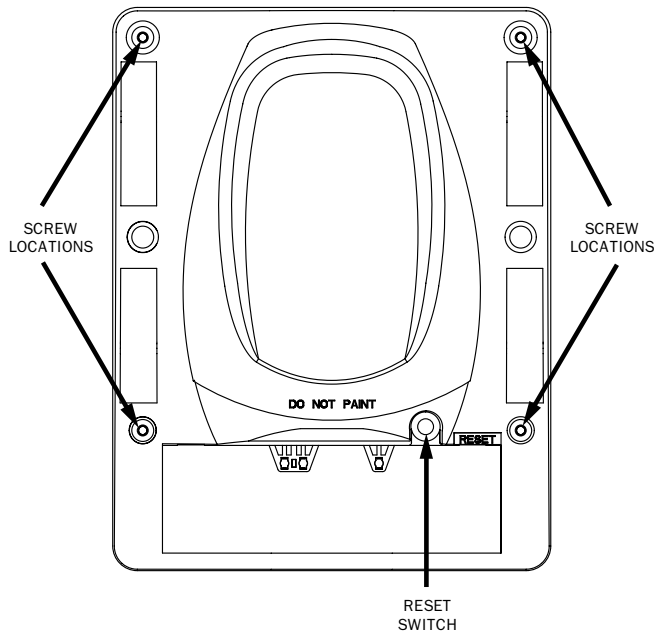

C0266-00

Figure 12. Coarse Alignment Procedure

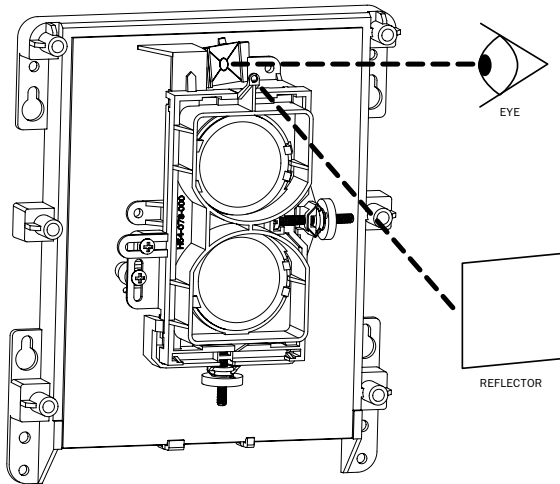

C0625-00

Sensitivity Selection

The detector has six sensitivity selections. Each of these selections is only acceptable over a specific distance separation between the detector and the reflector per UL268. The chart below is used to determine which selections are acceptable for your installed distance. The sensitivity of the detector can be set only when the housing is removed and the detector is not in the fine adjustment step of the alignment mode, indicated by the illumination of the dual digital display. To set the sensitivity depress the sensitivity button one time. See Figure 10. Once the switch is pressed the digital display will illuminate and read the current sensitivity setting in percent obscuration. To change the sensitivity continue to depress the sensitivity switch until the desired setting is achieved. The digital display will turn off automatically if no further switch presses occur.

Sensitivity Setting	% Obscuration	Display Reading	Acceptable Distance Between Detector and Reflector (Feet)	Acceptable Distance Between Detector and Reflector (meters)
Level 1	25	25	16.4 to 120	5.0 to 37.2
Level 2	30	30	25 to 150	7.6 to 46.6
Level 3	40	40	60 to 220	18.3 to 67
Level 4	50	50	80 to 328	24.4 to 100
Acclimate Level 1	30 to 50	A1	80 to 150	24.4 to 45.7
Acclimate Level 2	40 to 50	A2	80 to 220	24.4 to 67

In addition to the four standard sensitivity selections the detector has two Acclimate settings. When either of these settings is chosen the detector will automatically adjust its sensitivity using advanced software algorithms to select the optimum sensitivity for the environment. The sensitivity will be continuously adjusted within the ranges specified in the chart above.

Sensitivity

Total obscuration can be converted to percent per foot, assuming uniform smoke density for the entire length of the beam. The chart below converts total obscuration to percent per foot for all acceptable sensitivity settings.

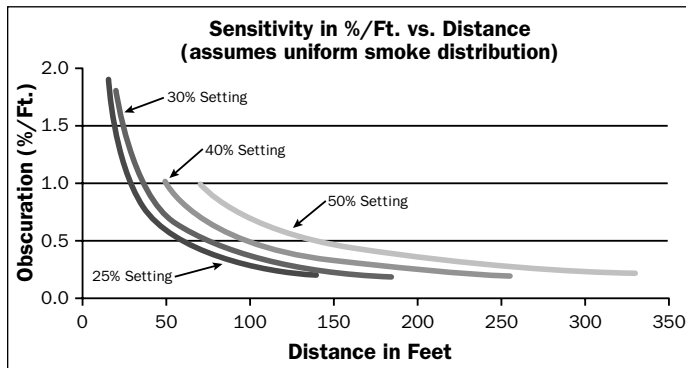

C0268-00

Sensitivity Testing

NOTE: Before testing, notify the proper authorities that the smoke detector system is undergoing maintenance, and therefore the system will be temporarily out of service. Disable the zone or system undergoing maintenance to prevent unwanted alarms.

Detectors must be tested after installation and following periodic maintenance. The sensitivity of the BEAM1224/BEAM1224S may be tested as follows:

NOTE: Before testing the detector, check for the presence of the flashing green LED at the receiver, making sure not to disturb or block the beam. If it does not flash and the detector is not in trouble or alarm, power has been lost to the detector (check the wiring).

A. Calibrated Test Filter

The sensitivity of the detector can be tested using an opaque material to cover the reflector by an amount indicated by the graduated scale on the reflector. (Due to the high optical efficiency of the reflector the selection of the opaque material used to block the reflector is not critical. Acceptable materials include, but aren't limited to, this manual or the cardboard packaging inserts.)

Refer to Figure 14 for this procedure.

1. Verify the sensitivity setting of the detector in % obscuration. See the Sensitivity Selection section of this manual for sensitivity determination if sensitivity is unknown.
2. Place the blocking material over the reflector, lining it up with the graduated marks that are 10 less than the detector's setting in percent obscuration. The detector should not alarm or fault. Keep the material in place for a minimum of 1 minute.
3. Place the blocking material over the reflector lining it up with the graduated marks that are 10 more than the detectors setting in percent obscuration. The detector should enter alarm within 1 minute.

Figure 14. Reflector Test Card Procedure

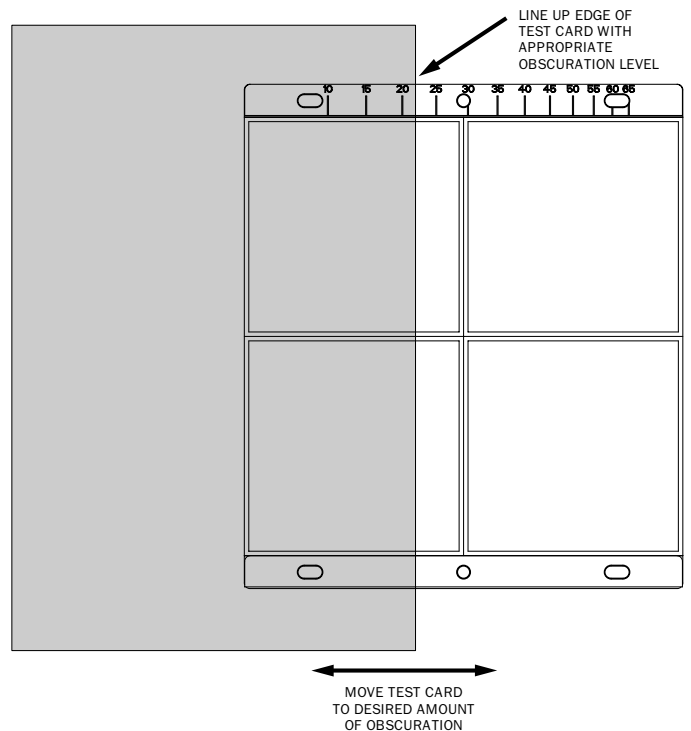

C0267-00

4. The detector can be reset with the reset switch on the detector unit, remote reset, or momentarily interrupting power.
5. Notify the proper authorities that the system is back on line.

If the detector fails this test several steps should be taken to determine if the detector is faulty or simply needs to be re-adjusted before returning the unit. These steps include:

1. Verify all wiring connections and appropriate power is applied to the detector.
2. Verify that the optical line of sight is free from obstructions and reflective objects.

3. Apply the maintenance procedure in this manual. Repeat the test procedure. If the detector still fails the test procedure proceed with step 4.
4. Repeat the alignment procedure in this manual. If the alignment procedure is successful repeat the test procedure. If the detector still fails the test it should be returned.

B. Test Switch

The detector can be tested using the local test switch on the transmitter/receiver unit or remotely using the remote test station.

The remote test station, RTS451 or RTS451KEY, can be used with the BEAM1224/BEAM1224S beam smoke detector. Follow instructions included with the test station for proper use. See Figure 8 (Remote Test Station) for wiring diagram.

The BEAM1224S is equipped with an integral sensitivity test feature that consists of a calibrated test filter attached to a servo motor inside the detector optics. When a test is initiated using the remote test station or local test switch the test filter is moved in the pathway of the light beam. The on-board microprocessor then determines if the proper level of signal reduction is received at the receiver. If the proper level of signal reduction is received the detector will enter alarm. If the proper level of signal reduction was not achieved, indicating that the sensitivity of the detector is out of tolerance, the detector will enter the trouble condition.

Always perform a complete reflector blockage test as in step 4 of the Installation/Alignment procedure to insure that the pathway between the detector and reflector is clear.

Note: For the BEAM1224 this test does not satisfy the requirements of NFPA72 for periodic maintenance and sensitivity verification of beam type detectors. For the BEAM1224S this test in conjunction with the complete reflector blockage test (see step 4 of the Installation/Alignment procedure in this manual) does satisfy the requirements of NFPA72 for periodic maintenance and sensitivity verification of beam type detectors.

If the detector fails this test several steps should be taken to determine if the detector is faulty or simply needs to be re-adjusted before returning the unit for repair. These steps include:

1. Verify all wiring connections and appropriate power is applied to the detector.
2. Verify that the optical line of sight is free from obstructions and reflective objects.
3. Apply the maintenance procedure in this manual. Repeat the test procedure. If the detector still fails the test procedure proceed with step 4.
4. Repeat the alignment procedure in this manual. If the alignment procedure is successful repeat the test procedure. If the detector still fails the test it should be returned.

Maintenance

NOTE: Before cleaning the detector, notify the proper authorities that the smoke detector system is undergoing maintenance, and therefore the system will be temporarily out of service. Disable the zone or system undergoing maintenance to prevent unwanted alarms.

1. Carefully clean the outer housing lens face. A damp soft cloth with a mild soap may be used. Avoid products with solvents or ammonia.
2. Carefully clean the reflector. A damp soft cloth with a mild soap may be used. Avoid products with solvents or ammonia.
3. Notify the proper authorities that the system is back on line.

Painting

The outer aesthetic ring may be painted using a spray or brush type paint of appropriate type. See specification section of this manual for paint types.

Note: never paint the flat lens surface of the outer housing.

Appendix I. Operation Modes and Troubleshooting Guide

Modes	Red	Yellow	Green	Dual Digital Display Readout	Initiating means	Alarm Contacts		Fault Contacts		Comments & Troubleshooting Tips
						Alarm	Remote	Trouble	Remote	
Normal	Off	Off	Blink	Off	Successful completion of initialization or detector reset	Open	OFF	Close	OFF	
Alignment	Off	On	Off	On, Relative amount of signal 0-99, or – if automatic gain resetting, or Lo if signal is too low	Alignment Switch	Open	OFF	Open	ON	
Alarm	On	Off	Off	Off	Smoke, Test Filter, RTS451/KEY	Close	ON	Close	OFF	
Trouble-Drift Comp Elevated Signal	Off	3 Quick Blinks	Blink	Off	Long Term Drift Reference Out of Range	Open	OFF	Open	ON	<ul style="list-style-type: none"> Sunlight into detector or reflector. Re-Align detector.
Trouble-Drift Comp Reduced Signal	Off	2 Quick Blinks	Blink	Off	Long Term Drift Reference Out of Range	Open	OFF	Open	ON	<ul style="list-style-type: none"> Clean detector and reflector.
Trouble-Signal Over Range	Off	2 Quick Blinks	Blink	Off	Increase of Reflected Signal	Open	OFF	Open	ON	<ul style="list-style-type: none"> Inspect line of sight between detector and reflector for reflective objects in the pathway.
Trouble-Beam Blockage Initial Response	Off	4 Quick Blinks	Off	Off	Beam Blockage	Open	OFF	Open	ON	<ul style="list-style-type: none"> Remove blockage. Faulty unit.
Trouble-Beam Blockage Long Term Response	On	4 Quick Blinks	Off	Off	Beam Blockage	Close	OFF	Open	ON	<ul style="list-style-type: none"> Remove blockage. Faulty unit.
Initialization-Power on	Off	Blink until complete	Blink	Off	Apply Power from discharged state.	Open	OFF	Close	OFF	
Initialization-alignment exit	Off	Blink until complete	Blink	Off	Depressing RESET switch after alignment	Open	OFF	Close	OFF	
Local Test (BEAM1224S) Pass Result	On	Off	Off	Off	RTS451/KEY	Close	ON	Close	OFF	Detector remains in alarm until reset or timeout
Local Test (BEAM1224S) Fail Result	Off	On until reset or timeout	Blink	Off	RTS451/KEY	Open	OFF	Open	ON	Detector remains in fault until reset or timeout
Local Test (BEAM1224) Fail Result	Off	Per fault mode	Blink	Off	RTS451/KEY	Open	OFF	Open	ON	If local test fails will already be in fault
Local Test (BEAM1224) Pass Result	On	Off	Off	Off	RTS451/KEY	Close	ON	Close	OFF	

Appendix II. Detector Drilling Template

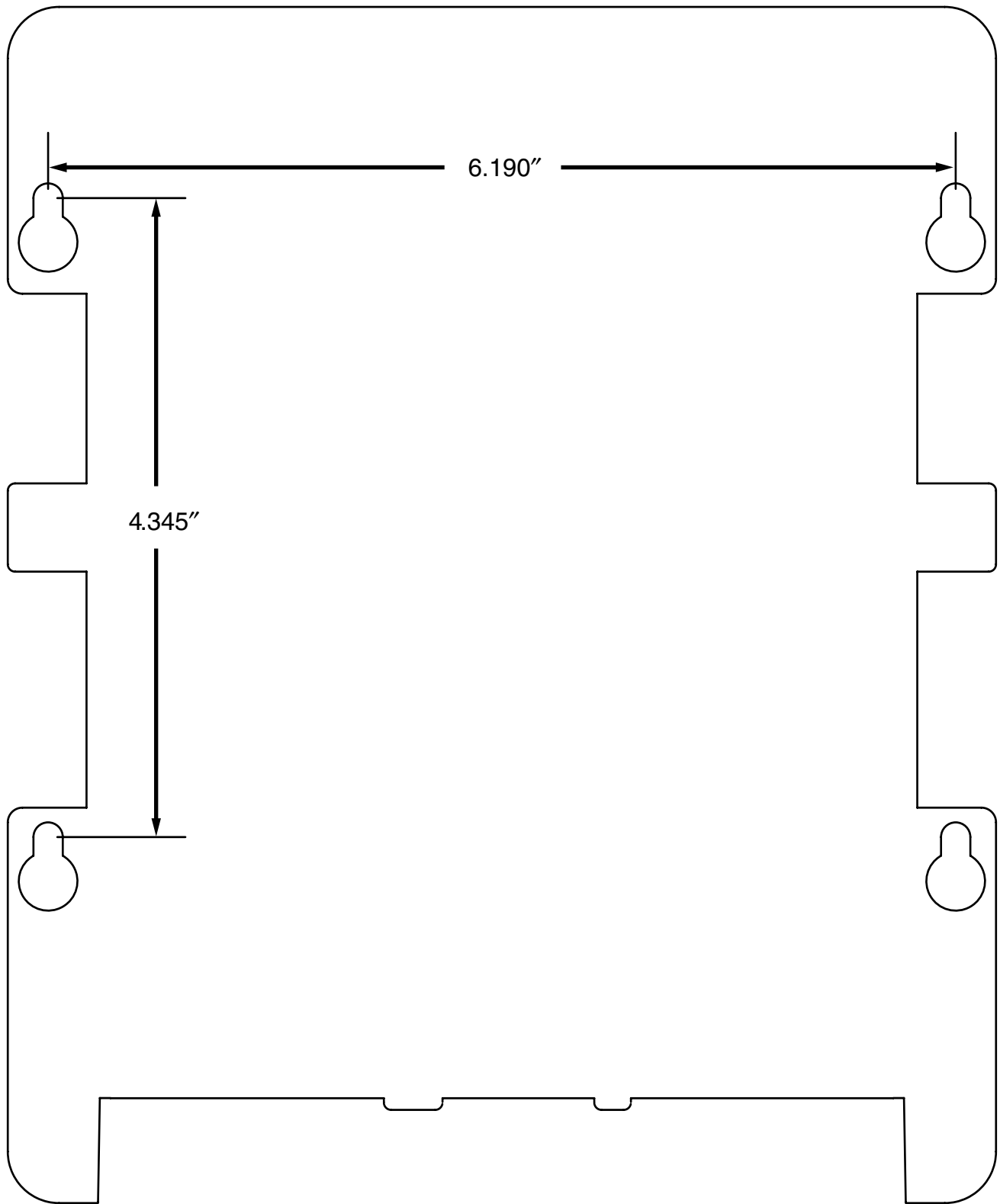

Scale = 1:1

Appendix III. Reflector Drilling Template

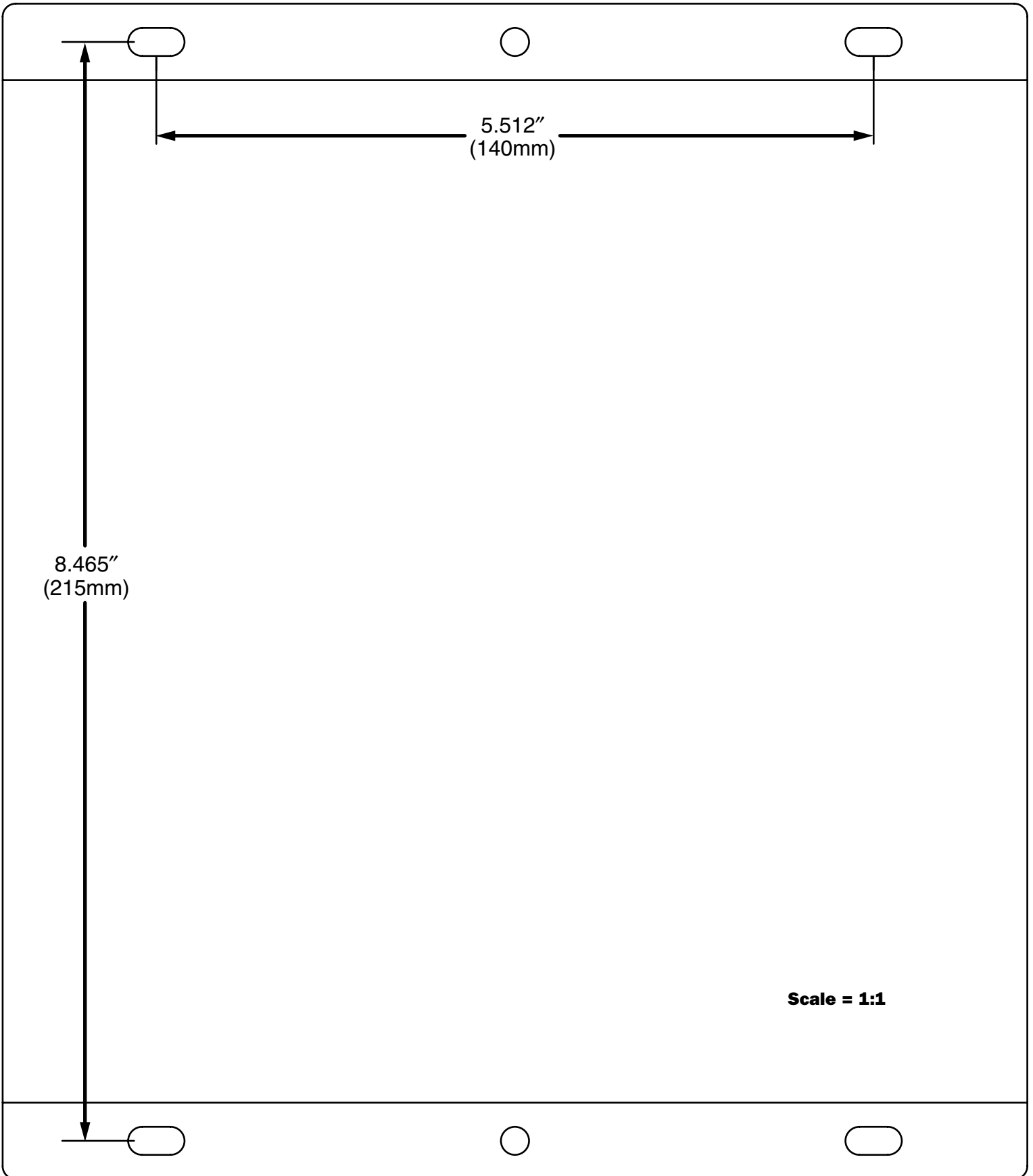

Please refer to insert for the Limitations of Fire Alarm Systems

FCC Statement

This device complies with part 15 of the FCC Rules. Operation is subject to the following two conditions: (1) This device may not cause harmful interference, and (2) this device must accept any interference received, including interference that may cause undesired operation.

Note: This equipment has been tested and found to comply with the limits for a Class B digital device, pursuant to Part 15 of the FCC Rules. These limits are designed to provide reasonable protection against harmful interference in a residential installation. This equipment generates, uses and can radiate radio frequency energy and, if not installed and used in accordance with the instructions, may cause harmful interference to radio communications. However, there is no guarantee that interference will not occur in a particular installation. If this equipment does cause harmful interference to radio or television reception, which can be determined by turning the equipment off and on, the user is encouraged to try to correct the interference by one or more of the following measures:

- Reorient or relocate the receiving antenna.
- Increase the separation between the equipment and receiver.
- Connect the equipment into an outlet on a circuit different from that to which the receiver is connected.
- Consult the dealer or an experienced radio/TV technician for help.

Three-Year Limited Warranty

System Sensor warrants its enclosed smoke detector to be free from defects in materials and workmanship under normal use and service for a period of three years from date of manufacture. System Sensor makes no other express warranty for this smoke detector. No agent, representative, dealer, or employee of the Company has the authority to increase or alter the obligations or limitations of this Warranty. The Company's obligation of this Warranty shall be limited to the repair or replacement of any part of the smoke detector which is found to be defective in materials or workmanship under normal use and service during the three year period commencing with the date of manufacture. After phoning System Sensor's toll free number 800-SENSOR2 (736-7672) for a Return Authorization number, send defective units postage prepaid to: System Sensor, Repair

Department, RA # _____, 3825 Ohio Avenue, St. Charles, IL 60174. Please include a note describing the malfunction and suspected cause of failure. The Company shall not be obligated to repair or replace units which are found to be defective because of damage, unreasonable use, modifications, or alterations occurring after the date of manufacture. In no case shall the Company be liable for any consequential or incidental damages for breach of this or any other Warranty, expressed or implied whatsoever, even if the loss or damage is caused by the Company's negligence or fault. Some states do not allow the exclusion or limitation of incidental or consequential damages, so the above limitation or exclusion may not apply to you. This Warranty gives you specific legal rights, and you may also have other rights which vary from state to state.