



3825 Ohio Avenue, St. Charles, Illinois 60174  
 1-800-SENSOR2, FAX: 630-377-6495  
 www.systemsensor.com

# DNR Duct Smoke Detector

## SPECIFICATIONS

Operating Temperature:	-4° to 158° F (-20° to 70° C)
Storage Temperature:	-22° to 158° F (-30° to 70° C)
Humidity:	0% to 93% Relative Humidity Non-condensing
Air Velocity:	100 to 4000 ft./min. (0.5 to 20.3 m/sec.)
Rectangular Footprint Dimensions:	14.38 in L x 5 in W x 2.5 in D (37 cm L x 12.7 cm W x 6.36 cm D)
Square Footprint Dimensions:	7.75 in L x 9 in W x 2.5 in D (19.7 cm L x 22.9 cm W x 6.35 cm D)
Weight:	1.6 pounds; 0.73 kg
Electrical (See applicable detector head installation manual for electrical specifications. Use the Base/Sensor Cross Reference chart at <a href="http://www.systemsensor.com">http://www.systemsensor.com</a> to determine applicable sensor head.)	

## Table of Contents

	Page
[1] Limitations of Duct Smoke Detectors . . . . .	1
[2] General Description . . . . .	1
[3] Contents of the Duct Smoke Detector Kit . . . . .	1
[4] Detector Installation . . . . .	1
[5] Sampling Tube Installation . . . . .	2
[6] Measurement Tests . . . . .	3
[7] Field Wiring . . . . .	4
[8] Verification of Operation . . . . .	4
[9] Detector Cleaning Procedures . . . . .	5
[10] Sensor Replacement . . . . .	5
[11] Optional Accessories . . . . .	5
Warranty . . . . .	6

ACCESSORY CURRENT LOADS AT 24 VDC		
DEVICE	STANDBY	ALARM
RA400Z	0mA	12mA Max.
RTS451	0mA	12mA Max.
RTS451KEY	12mA	12mA Max.

## BEFORE INSTALLING

Read the System Sensor Guide for *Proper Use of Smoke Detectors in Duct Applications* (A05-1004), which provides detailed information on detector spacing, placement, zoning, wiring, and special applications. Copies of this manual are available online at [www.systemsensor.com](http://www.systemsensor.com). NFPA Standards 72 and 90A should also be referenced for detailed information.

NOTICE: This manual shall be left with the owner/user of this equipment.  
 IMPORTANT: This detector must be tested and maintained regularly following NFPA 72 requirements. The detector should be cleaned at least once a year.

## [1] LIMITATIONS OF DUCT SMOKE DETECTORS



The National Fire Protection Association has established that DUCT DETECTORS MUST NOT BE USED AS A SUBSTITUTE FOR OPEN AREA DETECTOR PROTECTION as a means of providing life safety. Nor are they a substitute for early warning in a building's regular fire detection system.

System Sensor supports this position and strongly recommends that the user read NFPA Standards 90A, 72, and 101. The DNR Air Duct Smoke Detectors are listed per UL 268A.

This device will not operate without electrical power. Fire situations may cause an interruption of power. The system safeguards should be discussed with your local fire protection specialist.

This device will not sense smoke unless the ventilation system is operating and the cover is installed.

For this detector to function properly, it MUST be installed according to the instructions in this manual. Furthermore, the detector MUST be operated within ALL electrical and environmental specifications listed in this manual and the sensor head installation manual. Failure to comply with these requirements may prevent the detector from activating when smoke is present in the air duct.

## [2] GENERAL DESCRIPTION

Smoke introduced into this air duct system will be distributed throughout the entire building. Smoke detectors designed for use in air duct systems are used to sense the presence of smoke in the duct.

Model DNR Air Duct Smoke Detector utilizes photoelectric technology for the detection of smoke. This detection method, when combined with an efficient housing design, samples air passing through the duct and allows detection of a developing hazardous condition. When sufficient smoke is sensed, an alarm signal is initiated at the fire control panel monitoring the detector, and appropriate action can be taken to shut off fans, blowers, change over air handling systems, etc. These actions can facilitate the management of toxic smoke and fire gases throughout the areas served by the duct system.

The DNR incorporates a sensor cover tamper feature that provides a trouble signal at the panel immediately if the cover is removed or improperly installed. Proper installation of the sensor cover removes the trouble condition.

If programmed with the system control panel, two LEDs on each duct smoke detector light to provide local visible indication.

The DNR provides a remote alarm output for use with auxiliary devices, such as the RA400Z remote LED annunciator, as well as remote test capability with the RTS451 or RTS451KEY Remote Test Stations.

## [2.1] DETECTOR FEATURE SET

- Utilizes plug-in head
- Sampling tubes install from front and rear
- Compatible with existing accessories
- Able to address detector per code switches on sensor head.

## [3] CONTENTS OF THE DUCT SMOKE DETECTOR KIT

1. Sensor/power board assembly and covers (use appropriate sensor per the system control panel)
2. Three #10 sheet metal screws for mounting
3. One test magnet
4. Drilling template
5. One sampling tube end cap
6. One plastic exhaust tube

NOTE: A sampling tube must be ordered to complete the installation. It must be the correct length for the width of the duct where it will be installed. See Table 1 on page 3 to determine the inlet tube required for different duct widths.

## [4] DETECTOR INSTALLATION

### [4.1] VERIFY DUCT AIR FLOW DIRECTION AND VELOCITY

Model DNR detectors are designed to be used in air handling systems having air velocities of 100 to 4000 feet per minute. Duct widths from 6 inches to 12 feet can be accommodated. Be sure to check engineering specifications to ensure that the air velocity in the duct falls within these parameters. If necessary, use a velocity meter (anemometer) to check the air velocity in the duct.

**FIGURE 1. EXPLODED VIEW OF DUCT SMOKE DETECTOR COMPONENTS:**

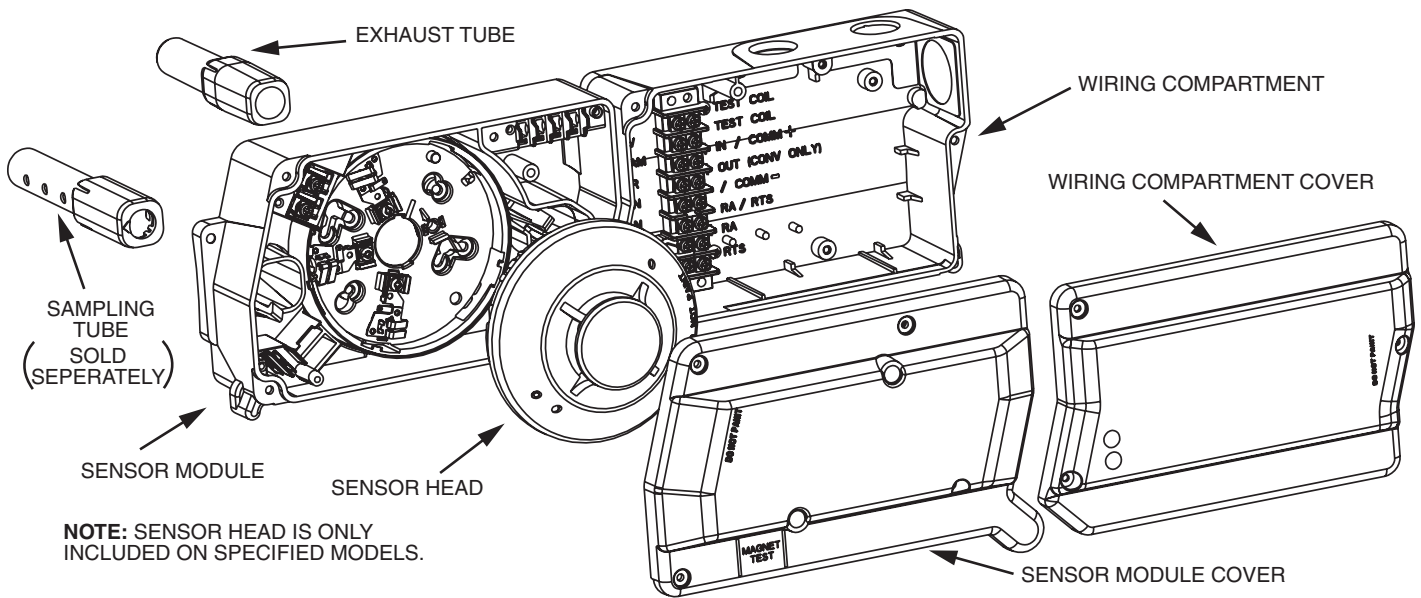

H0569-00

**[4.2] DETERMINE MOUNTING LOCATION AND CONFIGURATION**

On ducts wider than 18 inches it is recommended that the detector be mounted downstream of a bend, obstruction in the duct, or the supply or return air inlet.

Exception: Installation of duct detectors can be on or within a commercial packaged rooftop heating and air-conditioning system, fire/smoke dampers and economizers. They may be mounted in either the supply and/or return air section as determined by local code.

Once a suitable location is selected, determine if the detector is to be mounted in a side-by-side “rectangular” configuration or a top-over-bottom “square” configuration as shown in Figure 2. If mounting in the square configuration, remove the rear attachment screw, rotate the unit at hinge, and replace the screw into the new attachment hole as shown in Figure 2. Do NOT remove the hinge screw during this process. Final installation approval shall be based upon passing differential pressure and smoke entry tests described in the Measurement Tests section.

**FIGURE 2:**

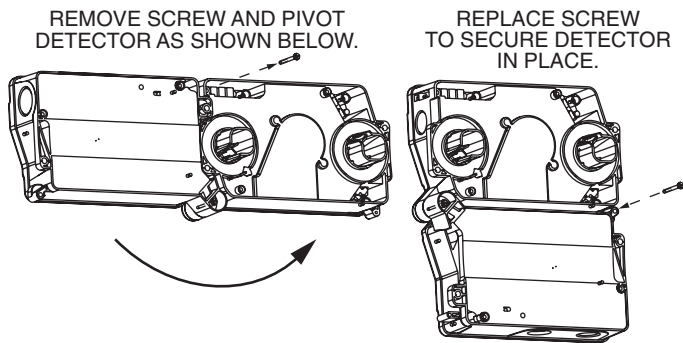

H0550-00

**[4.3] DRILL THE MOUNTING HOLES**

Remove the paper backing from the mounting template supplied. Affix the template to the duct at the desired mounting location. Make sure the template lies flat and smooth on the duct.

**[4.3.1] FOR RECTANGULAR SIDE-BY-SIDE MOUNTING CONFIGURATION:**

Center punch at (4) target centers: (2) “A” for sampling tubes and (2) “B” for the rectangular configuration mounting tabs as shown on mounting template. Drill pilot holes at target “A” centers and cut two 1.375 inch diameter holes using a 1 3/8 inch hole saw or punch. Drill .156 inch diameter holes using a 5/32 inch drill at target “B” centers.

**[4.3.2] FOR SQUARE TOP-OVER-BOTTOM MOUNTING CONFIGURATION:**

Center punch at (4) target centers: (2) “A” for sampling tubes and (2) “C” for the square configuration mounting tabs as shown on mounting template. Drill pilot holes at target “A” centers and cut two 1.375 inch diameter holes using a 1 3/8 inch hole saw or punch. Drill .156 inch diameter holes using a 5/32 inch drill at target “C” centers. If desired, drill an additional .156 inch hole at the location of one of the mounting tabs on the lower housing.

**[4.4] SECURE THE DUCT DETECTOR TO THE DUCT**

Use two (rectangular configuration) or three (square configuration) of the provided sheet metal screws to screw the duct detector to the duct.

CAUTION: Do not overtighten the screws.

**[5] SAMPLING TUBE INSTALLATION**

**[5.1] SAMPLING TUBE SELECTION**

The sampling tube must be purchased separately. Order the correct length, as specified in Table 1, for width of the duct where it will be installed. The sampling tube length must extend at least 2/3 across the duct width for optimal performance.

The sampling tube is always installed with the air inlet holes facing into the air flow. To assist proper installation, the tube’s connector is marked with an arrow. Make sure the sampling tube is mounted so that the arrow points into the airflow as shown in Figure 3. Mounting the detector housing in a vertical orientation is acceptable provided that the air flows directly into the sampling tube holes as indicated in Figure 3. The sampling tube and exhaust tube can be mounted in either housing connection as long as the exhaust tube is mounted downstream from the sampling tube.

**TABLE 1. SAMPLING TUBES RECOMMENDED FOR DIFFERENT DUCT WIDTHS:**

Outside Duct Width	Sampling Tube Recommended*
Up to 1 ft.	DST1
1 to 2 ft.	DST1.5
2 to 4 ft.	DST3
4 to 8 ft.	DST5
8 to 12 ft.	DST10 (2-piece)

\*Must extend a minimum of 2/3 the duct width

**FIGURE 3. AIR DUCT DETECTOR SAMPLING TUBE:**

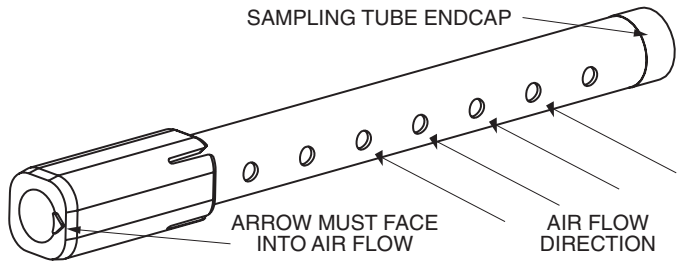

H0551-00

**CAUTION:** The sampling tube end cap, included with the detector, is critical to proper operation of the duct smoke detector. The end cap is needed to create the proper air flow to the sensor of the duct smoke detector. Once any sampling tube length adjustments are made, plug the end of the sampling tube with the provided end cap.

A plastic exhaust tube is included with the unit to be installed if needed. Install into the housing connection that is downstream from the sampling tube connection. The exhaust tube can be installed from the front of the detector or the back. A longer 1 foot exhaust tube, model ETX, is available as an accessory in cases where the molded exhaust tube does not extend at least 2 inches into the duct.

**[5.2] SAMPLING TUBE INSTALLATION**

- For tubes shorter than the width of the duct, slide the sampling tube, with installed end cap, into the housing connection that meets the air-flow first. Position the tube so that the arrow points into the airflow as shown in Figure 3. Per NFPA sampling tubes over 3 feet long should be supported at the end opposite of the duct detector. In ducts wider than 8 feet, work must be performed inside the duct to couple the other section of the sampling tube to the section already installed using the 1/2 inch conduit fitting supplied. Make sure that the holes on both sections of the air inlet sampling tube are lined up and facing into the airflow.
- For tubes longer than the width of the air duct, the tube should extend out of the opposite side of the duct. Drill a 3/4 inch hole in the duct opposite the hole already cut for the sampling tube. Ensure that the sampling tube is angled downward from the duct smoke detector to allow for moisture drainage away from the detector. The sampling tube should be angled at least 1/4" downward for every 12" of duct width per Figure 4. There should be 10 to 12 holes spaced as evenly as possible across the width of the duct. If there are more than 2 holes in the section of the tube extending out of the duct, select a shorter tube using Table 1. Otherwise, trim the tube to leave approximately 1 to 2 inches extending outside the duct. Plug the end with the end cap and tape closed any holes in the protruding section of the tube. Be sure to seal the duct where the tube protrudes.

**FIGURE 4.**

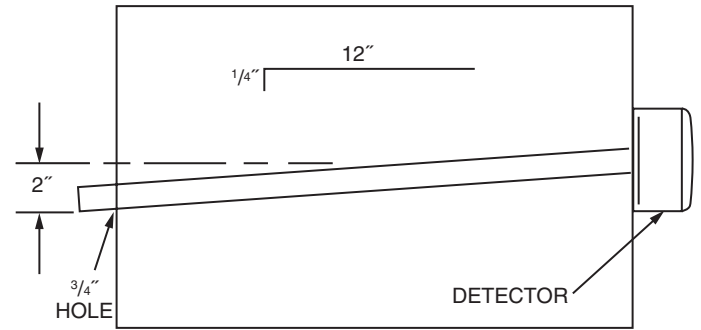

H0215-00

**NOTE:** Air currents inside the duct may cause excessive vibration, especially when the longer sampling tubes are used. In these cases, a 3 inch floor flange (available at most plumbing supply stores) may be used to fasten the sampling tube to the other side of the duct. When using the flange/connector mounting technique, drill a 1 to 1 1/4 inch hole where the flange will be used

**[5.3] MODIFICATIONS OF SAMPLING TUBES**

There may be applications where duct widths are not what is specified for the installation. In such cases, it is permissible to modify a sampling tube that is longer than necessary to span the duct width.

Use a 0.193-inch diameter (#10) drill and add the appropriate number of holes so that the total number of holes exposed to the air flow in the duct is 10 to 12. Space the additional holes as evenly as possible over the length of the tube.

**CAUTION:** This procedure should only be used as a temporary fix. It is not intended as a permanent substitute for ordering the correct length tubes.

**[5.4] REMOTE SAMPLING TUBE INSTALLATION**

The detector arrangement can also incorporate the remote mounting of the sampling tube and/or exhaust tube. In this case both the detector, sampling tube and exhaust tube (if included) should be rigidly mounted to withstand the pressure and vibrations caused by the air velocity. The location of the detector's sampling tube should be such that there is uniform airflow in the cross section area.

Pressure differential across the sampling and exhaust ports in the detector housing shall be verified to be between 0.01 and 1.11 inches of water. Do so by measuring the pressure difference between the inlet and outlet ports on the detector housing using a manometer as described in the Measurement Tests section of this manual.

**[6] MEASUREMENT TESTS**

**[6.1] AIR FLOW**

The DNR is designed to operate over an extended air speed range of 100 to 4000 FPM. To verify sufficient sampling of ducted air, turn the air handler on and use a manometer to measure the differential pressure between the two sampling tubes. The differential pressure should measure at least 0.01 inches of water and no more than 1.11 inches of water. Because most commercially

**FIGURE 5. PROCEDURE FOR VERIFYING AIR FLOW:**

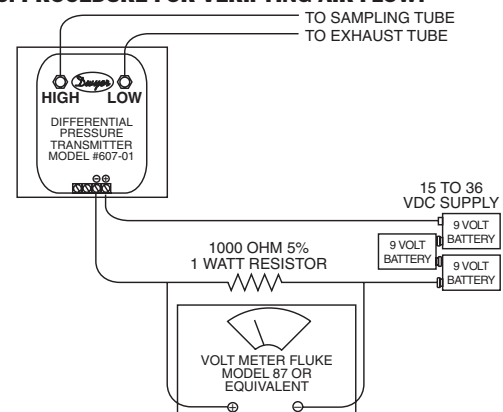

H0163-01

available manometers cannot accurately measure very low pressure differentials, applications with less than 500 FPM of duct air speed may require one of the following: 1) the use of a current-sourcing pressure transmitter (Dwyer Series 607) or 2) the use of aerosol smoke, see below for test descriptions.

**[6.2]LOW FLOW AIR FLOW TEST USING DWYER SERIES 607 DIFFERENTIAL PRESSURE TRANSMITTER**

Verify the air speed of the duct using an anemometer. Air speed must be at least 100 FPM. Wire the Dwyer transmitter as shown in Figure 5. Connect the leads of the meter to either side of the 1000Ω resistor. Allow unit to warm up for 15 seconds. With both HIGH and LOW pressure ports open to ambient air, measure and record the voltage drop across the 1000Ω resistor (measurement 1), 4.00 volts is typical. Using flexible tubing and rubber stoppers, connect the HIGH side of the transmitter to the sampling tube of the duct smoke detector housing, and the LOW side of the transmitter to the exhaust tube of the duct smoke detector housing. Measure and record the voltage drop across the 1000Ω resistor (measurement 2). Subtract the voltage recorded in measurement 1 from the voltage recorded in measurement 2. If the difference is greater than 0.15 volts, there is enough air flow through the duct smoke detector for proper operation.

**[7]FIELD WIRING; INSTALLATION GUIDELINES**

All wiring must be installed in compliance with the National Electrical Code and the local codes having jurisdiction. Proper wire gauges should be used. The conductors used to connect smoke detectors to control panels and accessory devices should be color-coded to prevent wiring mistakes. Improper connections can prevent a system from responding properly in the event of a fire.

For signal wiring (the wiring between detectors or from detector to auxiliary devices), it is usually recommended that single conductor wire be no smaller than 18 gauge. The duct smoke detector terminals accommodate wire sizes up to 12 gauge. Flexible conduit is recommended for the last foot of conduit; solid conduit connections may be used if desired.

Duct smoke detectors and alarm system control panels have specifications for Signaling Line Circuit (SLC) wiring. Consult the control panel manufacturer's specifications for wiring requirements before wiring the detector loop.

**[7.1]WIRING INSTRUCTIONS**

Disconnect power from the communication line before installing the DNR duct smoke detector.

The DNR detectors are designed for easy wiring. The housing provides a terminal strip with clamping plates. Wiring connections are made by sliding the bare end under the plate, and tightening the clamping plate screw. See Figure 6 on below for system wiring.

**FIGURE 6. SYSTEM WIRING DIAGRAM FOR DNR:**

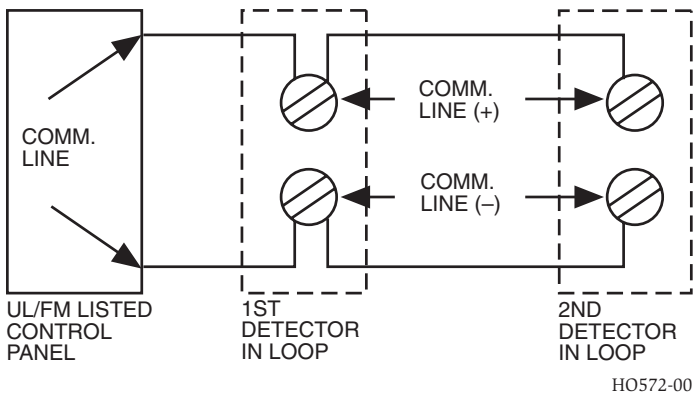

**[7.2] SET THE ADDRESS**

Set the desired address on the sensor head code wheel switches. on the back of the sensor head.

**FIGURE 7. ROTARY ADDRESS SWITCHES**

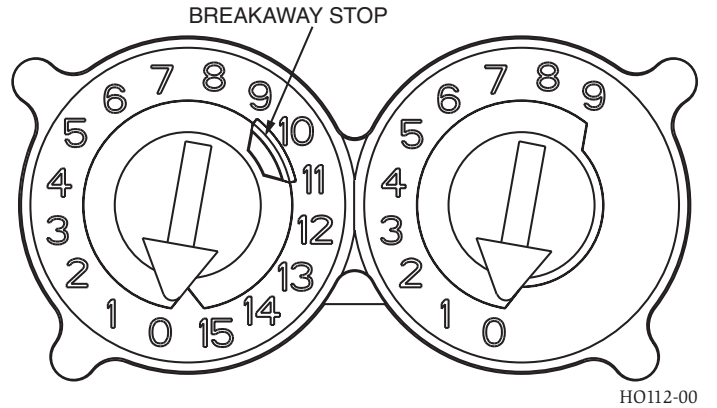

**Note:** Some panels support extended addressing. In order to set the sensor above the address number 99 on compatible systems, carefully remove the stop on the left hand rotary switch with pliers as shown in Figure 7.

**NOTE:** Verify sensor cover gasket is properly seated on cover prior to cover installation

**[8] VERIFICATION OF OPERATION**

**[8.1]INSTALL THE COVER**

Install the covers making sure that the cover fits into the base groove. Tighten the seven screws that are captured in the covers. Note that the cover must be properly installed for proper operation of the sensor.

**NOTE:** Verify sensor cover gasket is properly seated on cover prior to cover installation.

**[8.2] POWER THE UNIT**

Activate the communication line on terminals COM + and COM —.

**[8.3] DETECTOR CHECK**

**Standby** - If programmed by the system control panel, look for the presence of the flashing LEDs through the transparent housing cover. The LED will flash with each communication.

**Trouble** - If programmed by the system control panel and the detector LEDs do not flash, then the detector lacks power (check wiring, missing or improperly placed cover, panel programming, or power supply), the sensor head is missing (replace), or the unit is defective (return for repair).

**[8.4]DUCT SMOKE DETECTOR TEST & MAINTENANCE PROCEDURES**

Test and maintain duct smoke detectors as recommended in NFPA 72. The tests contained in this manual were devised to assist maintenance personnel in verification of proper detector operation.

Before conducting these tests, notify the proper authorities that the smoke detection system will be temporarily out of service. Disable the zone or system under test to prevent unwanted alarms.

**[8.4.1]TEST THE UNIT**

1. M02-04-00 Magnet Test - This sensor can be functionally tested with a test magnet. The test magnet electronically simulates smoke in the sensing chamber, testing the sensor electronics and connections to the control panel.
2. Remote Test Accessory - The use of a remote accessory for visible indication of power and alarm is recommended.

Verify system control panel alarm status and control panel execution of all intended auxiliary functions (i.e. fan shutdown, damper control, etc.).

Two LEDs on the sensor are controlled by the panel to indicate sensor status. Coded signals, transmitted from the panel, can cause the LEDs to blink, latch on, or latch off. Refer to the control panel technical documentation for sensor LED operation and expected delay to alarm.

**[8.4.2] THE DETECTOR MUST BE RESET BY THE SYSTEM CONTROL PANEL**

**[8.4.3] SMOKE ENTRY TEST USING AEROSOL SMOKE**

This test is intended for low-flow systems (100-500 FPM). If the air speed is greater than 500 FPM, use a conventional manometer to measure differential pressure between the sampling tubes, as described under Measurement Tests on Page 3.

Drill a 1/4 inch hole 3 feet upstream from the duct smoke detector. With the air handler on, measure the air velocity with an anemometer. Air speed must be at least 100 FPM. Spray aerosol smoke\* into the duct through the 1/4 inch hole for five seconds. Wait two minutes for the duct smoke detector to alarm. If the duct smoke detector alarms, air is flowing through the detector. Remove the duct smoke detector cover and blow out the residual aerosol smoke from the chamber and reset the duct smoke detector at the panel. Use duct tape to seal the aerosol smoke entry hole. Remember to replace the cover after the test or the detector will not function properly.

\*Aerosol smoke can be purchased from Home Safeguard Industries, model 25S Smoke Detector Tester, Malibu, CA. Phone: 310/457-5813 and Chekkit Smoke Detector Tester model CHEK02 and CHEK06 available from SDi. When used properly, the canned smoke agent will cause the smoke detector to go into alarm. Refer to the manufacturer's published instructions for proper use of the canned smoke agent.

**CAUTION**

Canned aerosol simulated smoke (canned smoke agent) formulas will vary by manufacturer. Misuse or overuse to these products may have long term adverse effects on the smoke detector. Consult the canned smoke agent manufacturer's published instructions for any further warnings or caution statements.

**[9] DETECTOR CLEANING PROCEDURES**

Notify the proper authorities that the smoke detector system is undergoing maintenance, and that the system will temporarily be out of service. Disable the zone or system undergoing maintenance to prevent unwanted alarms and possible dispatch of the fire department.

**[9.1] DETECTOR SENSOR**

1. Remove the sensor to be cleaned from the system.
2. Remove the sensor cover by pressing firmly on each of the four removal tabs that hold the cover in place.
3. Vacuum the screen carefully without removing it. If further cleaning is required continue with Step 4, otherwise skip to Step 7.
4. Remove the chamber cover/screen assembly by pulling it straight out.
5. Use a vacuum cleaner or compressed air to remove dust and debris from the sensing chamber.
6. Reinstall the chamber cover/screen assembly by sliding the edge over the sensing chamber. Turn until it is firmly in place.
7. Replace the cover using the LEDs to align the cover and then gently pushing it until it locks into place.
8. Reinstall the detector.

**[9.2] REINSTALLATION**

1. Reinstall the detector in its housing.
2. Restore system power.
3. Perform Detector Check.
4. Notify the proper authorities testing has been completed and the smoke detector system is back in operation.

**[10] SENSOR REPLACEMENT**

1. Remove the sensor head by rotating counterclockwise.
2. Pull gently to remove it.
3. To replace the sensor head, align the mounting features and rotate clockwise into place.

**[11] OPTIONAL ACCESSORIES**

Optional accessories include RA400Z, RTS451 and RTS451KEY

**FIGURE 8. WIRING DIAGRAM FOR DNR TO RA400Z:**

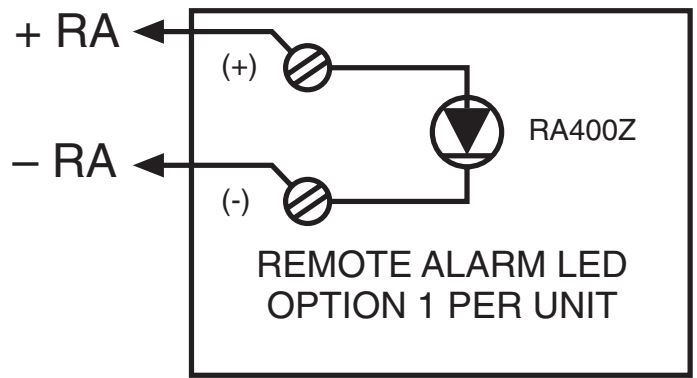

H0570-00

Note: Tab on the RA400Z should be broken for use with the intelligent duct smoke detector.

**[11.1] RTS451/RTS451KEY REMOTE TEST STATION**

The RTS451/RTS451KEY Remote Test Station facilitates test of the alarm capability of the duct smoke detector. These accessories provide the stimulus to initiate an alarm condition at the detector. The DNR duct smoke detector must be reset by the system control panel. To install the RTS451/RTS451KEY, connect the device as shown in Figure 9 below; wire runs must be limited to 25 ohms or less per interconnecting wire.

**NOTE:** The use of a remote test station requires the installation of an accessory coil, part number DCOIL, sold separately.

- 1) Install DCOIL in housing pocket insuring that arrow is pointing toward detector
  - 2) Install DCOIL mounting screw
  - 3) Connect each DCOIL lead to a Test Coil Terminal
- See Figure 8 below for reference.

**FIGURE 8. DNR WITH OPTIONAL TEST COIL**

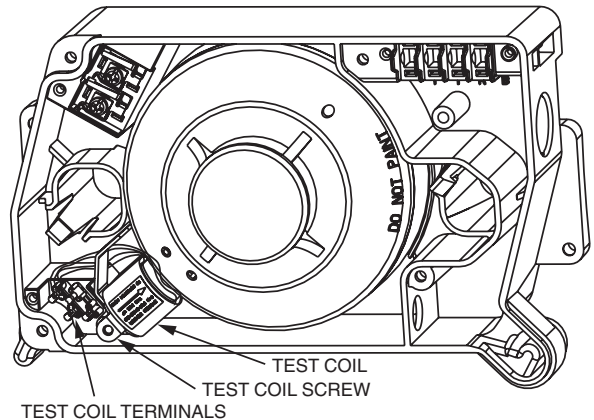

H0561-00

**FIGURE 9. WIRING DIAGRAM FROM DNR TO RTS451/RTS451KEY:**

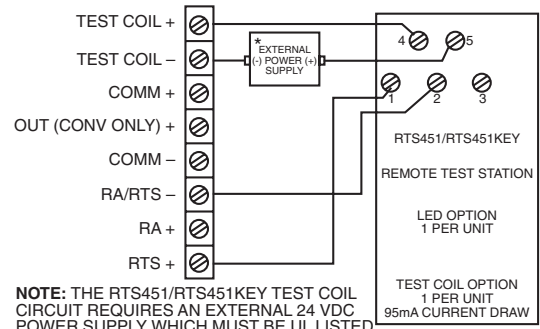

**NOTE:** THE RTS451/RTS451KEY TEST COIL CIRCUIT REQUIRES AN EXTERNAL 24 VDC POWER SUPPLY WHICH MUST BE UL LISTED.

**NOTE:** THE USE OF A REMOTE TEST STATION REQUIRES THE INSTALLATION OF AN ACCESSORY COIL, PART NUMBER DCOIL, SOLD SEPARATELY.

H0571-01

**Please refer to insert for the Limitations of Fire Alarm Systems**

**THREE-YEAR LIMITED WARRANTY**

System Sensor warrants its enclosed product to be free from defects in materials and workmanship under normal use and service for a period of three years from date of manufacture. System Sensor makes no other express warranty for the enclosed product. No agent, representative, dealer, or employee of the Company has the authority to increase or alter the obligations or limitations of this Warranty. The Company's obligation of this Warranty shall be limited to the replacement of any part of the product which is found to be defective in materials or workmanship under normal use and service during the three year period commencing with the date of manufacture. After phoning System Sensor's toll free number 800-SENSOR2 (736-7672) for a Return Authorization number, send defective units postage prepaid to: System Sensor, Returns Department, RA

# \_\_\_\_\_, 3825 Ohio Avenue, St. Charles, IL 60174. Please include a note describing the malfunction and suspected cause of failure. The Company shall not be obligated to replace units which are found to be defective because of damage, unreasonable use, modifications, or alterations occurring after the date of manufacture. In no case shall the Company be liable for any consequential or incidental damages for breach of this or any other Warranty, expressed or implied whatsoever, even if the loss or damage is caused by the Company's negligence or fault. Some states do not allow the exclusion or limitation of incidental or consequential damages, so the above limitation or exclusion may not apply to you. This Warranty gives you specific legal rights, and you may also have other rights which vary from state to state.