

6200 INTELLIGENT OPTICAL SMOKE BEAM DETECTOR

FEATURES

- Combined transmitter and receiver unit
- Can be connected directly to the analogue addressable loop
- Range 10-100 metres
- Sensitivity/threshold adjustment
- Operates in the visible light spectrum
- Visual LED indicators to aid alignment of beam
- Standby, fault and alarm LED indicators
- Integral horizontal and vertical beam alignment
- Drift compensation
- Optional - Remote engineer's switch
- Optional - Heat pad kits and filters
- VdS approved
- Tested and approved to prEN54-12 and EN60825-1 Laser Safety Standard
- Extended Warranty

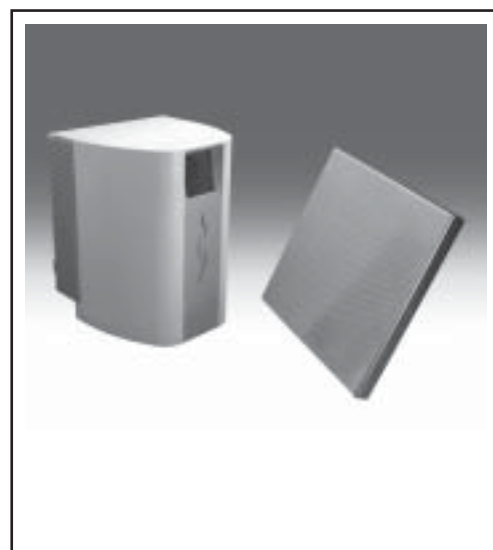

G201039

DESCRIPTION

The model 6200 is an intelligent reflector- type linear optical beam smoke detector designed to operate as a component of an intelligent fire alarm system. It operates primarily on the principle of light obscuration utilising a non-dangerous Class IIIA laser beam. Optical beam smoke detectors are particularly appropriate for protecting buildings with large open spaces such as warehouses, atriums etc.

The 6200 detector is a combined transmitter/receiver unit, which can be directly connected to an analogue addressable loop without the need of a local power supply. Each second the laser diode within the detector generates a visible pulsed light towards a high efficiency reflector. The reflector returns the beam to the 6200 detector receiver where an analysis of the received signal is made. The change in the strength of the received signal is used to determine the alarm condition.

The 6200 detector provides considerable savings in installation costs, as the installer only needs to terminate the loop cabling to the detector, with no separate wiring for individual transmitter and receiver units or local power supplies.

There are five reflectors used in conjunction with the 6200 detector, the REFL20, REFL30, REFL40, REFL50 and REFL60 providing a range of 10 to 100m and a choice of aluminium or ABS mounting frames.

Alignment of the 6200 detector is simplified with the aid of the detector's installation set up. During commissioning the detector can be put into installation mode by means of a switch. Selecting this mode provides the installer with a visible targeting spot of light. Alignment of the 6200 detector with the reflector can then be "fine tuned" with the aid of alignment LED indicators.

The 6200 detector has an advanced sensitivity adjustment feature providing application flexibility to suit the environment in which the detector will be installed. The sensitivity adjustment has five different settings for this purpose.

EUROPEAN HEADQUARTERS
SYSTEM SENSOR EUROPE
 3 HORSHAM GATES
 HORSHAM
 WEST SUSSEX
 RH13 5PJ
 UNITED KINGDOM
 TEL: +44 (0)1403 276500
 FAX: +44 (0)1403 276501
 EMAIL: sales@sseuk.com

EUROPEAN MANUFACTURING CENTRE
PITWAY TECNOLOGICA SPA
 VIA CABOTO 19/3
 34147 TRIESTE
 ITALY

TEL: +39 040 9490111
 FAX: +39 040 382137

www.systemsensoreurope.com



The 6200 detector incorporates automatic drift compensation, whereby the detector will adjust its detection thresholds in line with any reduced signal of the beam caused by environmental contaminants. Once the detector reaches its compensation limit, the condition can be identified by the Fire Alarm Panel.

A remote engineer's switch can be connected to the 6200 detector. It provides visible indication of the 6200 detector's condition along with a local isolation and test facility. This unit provides obvious advantages when the detector is installed at a high level.

The 6200 detector can also adjust its alignment to compensate for inclined walls and surfaces. The 6200 detector can be adjusted up to 10° vertically and horizontally and the reflector can be out of alignment by up to 15° horizontally and vertically to cater for such walls and surfaces. If the angle is greater than these parameters, then an orientation bracket kit (6200-OBK) can be used for accurate alignment.

There are various other accessories available for the 6200 detector. A 6200 Filter unit is supplied with all 6200 detectors, which provides an easy and simple way to test the 6200 detector. When placed in the beam path it provides a change in the signal back to the 6200 detector receiver and initiates a fire condition. 6200-C heating pad kits can also be supplied which minimise condensation being formed on the 6200 detector and reflector surfaces (aluminium reflectors only).

All System Sensor products are covered by our extended 3 year warranty.

INSTALLATION RECOMMENDATIONS

Installation should be undertaken in accordance with recognised international standards and codes of practice. The recommendations detailed in our "Guide to the Proper use of Projected Beam Smoke Detectors" (I56-506) should also be taken in to consideration.

We would also recommend that simulated fire tests are conducted to ensure that the desired response time for a given installation are met.

REMOTE ALARM UNIT - 6200BR

The 6200BR provides the following features:

- "Alarm" LED
- "Fault /Dirty" LED
- 3 Position Key Switch
- Test Points
- Detector Reset/Disable
- Alarm Test

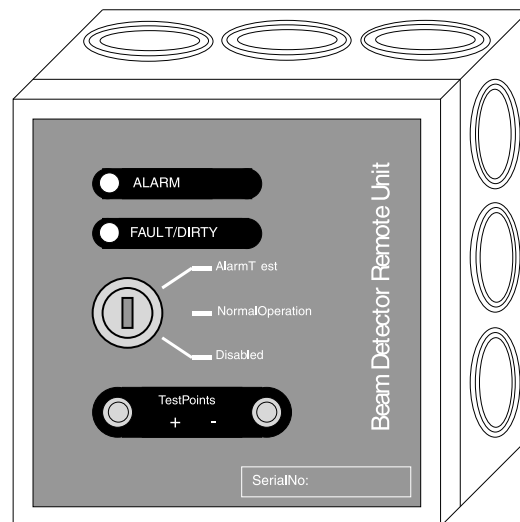

The 6200BR is a remote indication and control unit Beam Detector. It has been designed to provide easier operation and maintenance of the detector when the detector is mounted in a location where access is difficult. The 3 - Position Key Switch provides direct control over the status of the detector. The three positions are:

Alarm Test - When the Key is switched into the alarm position. The alarm will be indicated on the remote box, on the detector and at the Fire Control Panel.

Disabled - When the key is switched into the disabled position the detector will be prevented from generating an alarm. A fault signal will be indicated on the remote box, on the detector and at the Fire Control Panel.

Normal Operation - Resets the detector to its normal operating mode.

The test points provide a means of comparing the level of the raw returned signal.

Only one 6200BR remote box can be connected to a 6200 Optical Beam Detector. Only one 6200 Optical Smoke Beam Detector can be connected to a 6200BR remote box.

6200 INTELLIGENT OPTICAL BEAM SMOKE DETECTOR

SPECIFICATIONS

Electrical

Operating Voltage Range	17 to 28V (24 VDC nominal)
Maximum Standby Current	3.2mA
Maximum Alarm Current (LED on)	12mA

Mechanical

	6200	REFL20	REFL30	REFL40	REFL50	REFL60
Height	195mm	205mm	305mm	400mm	548mm	600mm
Length	155mm	205mm	305mm	400mm	508mm	600mm
Width	150mm	30mm	30mm	30mm	30mm	30mm
Weight	1kg	0.5kg	1.1kg	1.2kg	3.6kg	1.6kg
Colour	Grey	Grey	Grey	White	Grey	White
Material	ABS	Al/ABS	Al/ABS	ABS	Al/ABS	ABS
Cable Connection	Via Knockouts					

Optical

	6200	REFL20	REFL30/40	REFL50/60
Range	N/A	10 to 30m	30 to 50m	30 to 100m
Wavelength	670nm (red)			
Horizontal/Vertical Alignments	+/-10° Vertical, +/-15° Horizontal			

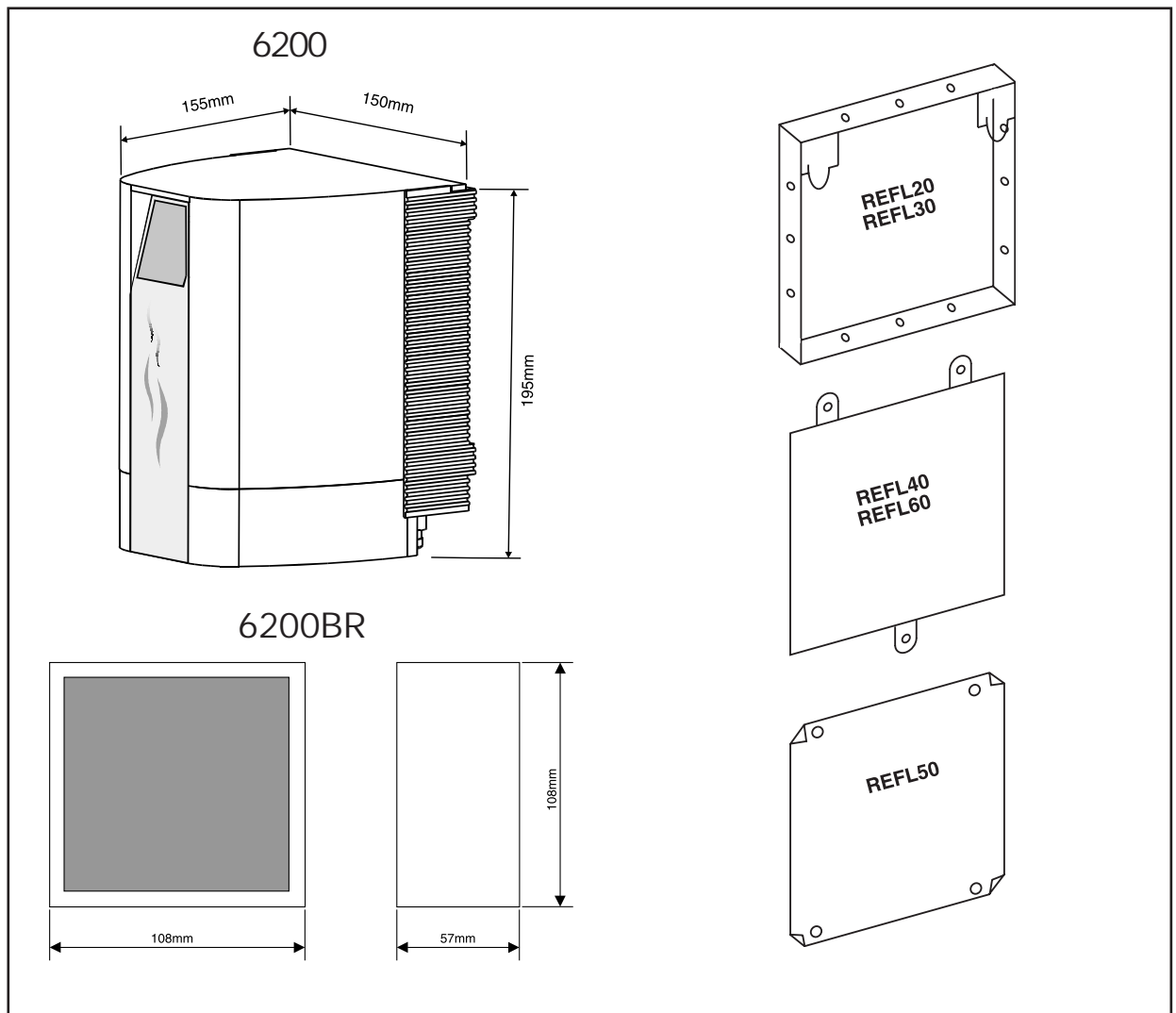

6200BR REMOTE ALARM UNIT

Mechanical Specifications

Parameters

Weight	200g
Overall Dimensions	108(H) x 108(L) x 57(W)mm
Protection Index	IP42 when suitably mounted
Colour	Cool grey RAL7035
Mounting	Screws at housing fixing
Cover Fixing	Clip-on
Cable Termination	12 Knock-outs

Climatic Specifications

Operating Temperature	-10°C to +55°C
Storage Temperature	-10°C to +55°C
Operating maximum relative humidity	<95% without condensation
Storage maximum relative humidity	<85% without condensation

Electrical Specification

Power supply from the detector	(max cable length: 100m)
--------------------------------	--------------------------

Note: The use of 6200BR does not increase the power consumption of the detector.

Product Range

Other accessories for the 6200 include:

Accessories

REFL20	Short to Medium Range Reflector – metal backplate
REFL30	Medium Range Reflector – metal backplate
REFL40	Medium Range Reflector – ABS backplate
REFL50	Medium Range to Long Range Reflector – metal backplate
REFL60	Long Range Reflector – ABS backplate
6200-OBK	Orientation Bracket Kit
6200-C	Heating Pad Kit for 6200 detector
REFL20-C	Heating Pad Kit suitable for REFL20 and REFL30
REFL50-C	Heating Pad Kit suitable for REFL50
6200BR	Remote Unit for 6200

Other Detectors:

6200R	Conventional Optical Smoke Beam Detector
-------	--