



LED Display Relay Board



The **Pertronic LED Display Relay Board** is connected to the bus of a 12-way LED or Global LED display board. The **LED Relay Board** contains 8 non-latching relays that correspond to LED position numbers in the display. (Up to 255 for **F100A** systems and to 512 for **F120** systems). Multiple **LED Relay Boards** may be used.

Each relay provides change-over contacts (no-c-nc), rated 1A, 30V dc. The relay contacts are not monitored.

An active relay will remain steady (will not 'flash' as the LEDs do when active), and the relays will remain in their current state when the LED test function is operating.

Specification:

Dimensions

PCB, 96L x 38W (mm)

Has same mounting footprint as the 8-way LED Display Board.

Power Supply

24V dc – derived from the LED Display bus

Operating current:

No activation: 5mA @ 5V

1.2mA @ 27V

Add for each active relay:

8.5mA @ 27V

Connection

Anywhere on the display bus of the LED display board. (12 way LED Display Board or Global Display Board).

Relay Characteristics

8 relays with screw terminals for change-over contacts (no-n-c).

The relay contacts are not monitored.

Contact rating –1A, 30V dc.

Software Compatibility

The 12-way LED and Global Display Boards must have V3.01 software or greater.

The LED Display Relay Board must have software V2.00 or greater.

Connection Diagram:

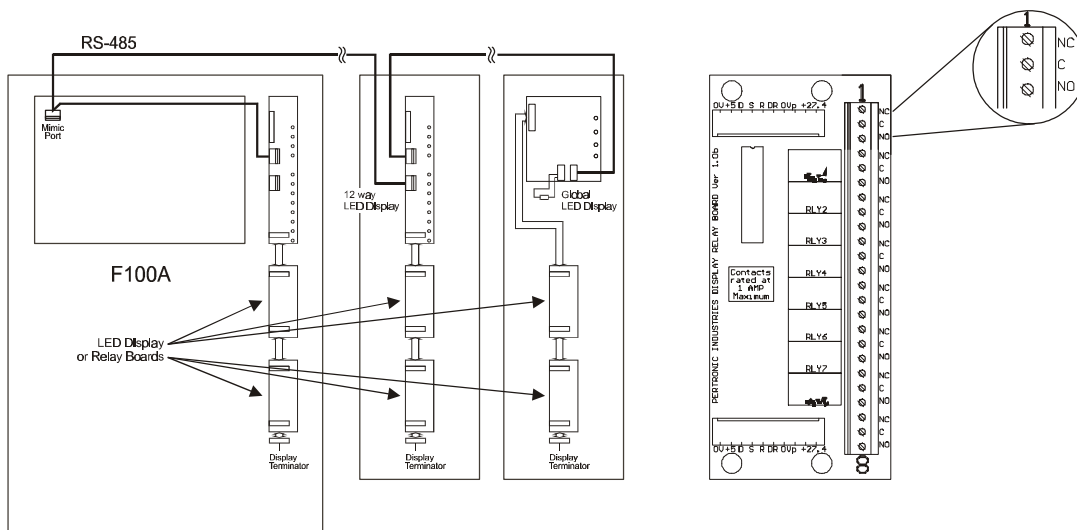

Firetronix and Pertronic are registered trademarks of Pertronic Industries Ltd

PERTRONIC INDUSTRIES LTD
20 Eastern Hutt Road, Wingate, Lower Hutt
P.O. Box 35-063, Wellington, New Zealand

Telephone: (64) 4 567 3229
Fax: (64) 4 567 3644
email: sales@pertronic.co.nz